

SANMOTION

SERVO SYSTEMS

R **ADVANCED
MODEL**

AC 100 V 30 W - 200 W, AC 200 V 30 W - 15 kW



SANYO DENKI

SANMOTION R

SERVO SYSTEMS

ADVANCED MODEL

Input voltage **AC100 V, 200 V**

Servo amplifier



Amp.capacity 15A · 30A · 50A · 100A · 150A · 300A

Servo motor



Flange size 40mm sq. · 60mm sq. · 80mm sq. · 86mm sq. · 100mm sq. ·
120mm sq. · 130mm sq. · 180mm sq. · 220mm sq.



Rated output 30W · 50W · 80W · 100W · 200W · 400W · 550W ·
750W · 1.0kW · 1.2kW · 1.5kW · 1.8kW · 2.0kW ·
2.5kW · 3.0kW · 3.5kW · 4.0kW · 4.5kW · 5.0kW ·
5.5kW · 7.0kW · 7.5kW · 11kW · 15kW



Index

Features	P. 3
Standard Model Number List	P. 7
Model Number Nomenclature	P. 15
System Configuration	P. 17
Servo Amplifier Specifications	P. 21
General-Purpose Output Specifications	P. 22
Specifications - Servo Amplifier+	
R2 Servo Motor (Medium Inertia)	P. 23
Q2 Servo Motor (Medium Inertia)	P. 33
R1 Servo Motor (Low Inertia)	P. 35
Q1 Servo Motor (Low Inertia)	P. 37
Encoder Wiring Diagram	P. 41
External Wiring Diagram	P. 42
Dimensions	P. 44
R2 Servo Motor (Medium Inertia)	P. 44
R1 Servo Motor (Low inertia)	P. 48
Q2 Servo Motor (Medium Inertia)	P. 49
Q1 Servo Motor (Low Inertia)	P. 49
Servo Amplifier	P. 51
Setup Software	P. 53
Option	P. 55

50% Shorter Position Settling Time [※]

The vibrations of the low rigidity machine stand resonance is minimized, and shortens positioning settling time. The amplifier is suitable for chip mounters and equipment needs high speed positioning.

※ Compared with our conventional product "SANMOTION R".

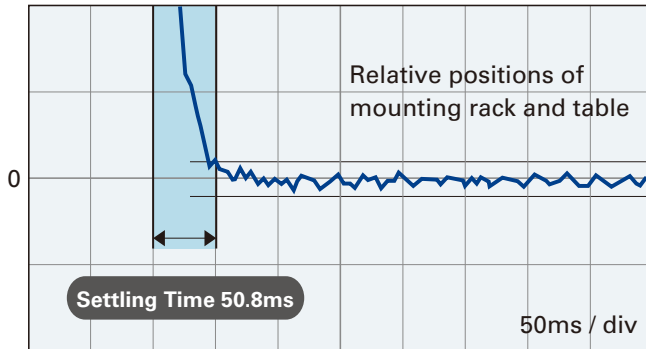

Our conventional product

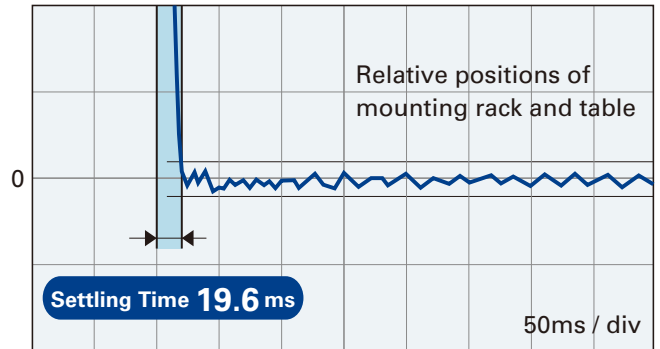

SANMOTION R ADVANCED MODEL

Doubled Frequency Response Limit

The frequency response limit has been increased to 1200 Hz, twice the limit of our current model. [※]

※ Compared with our conventional product "SANMOTION R".

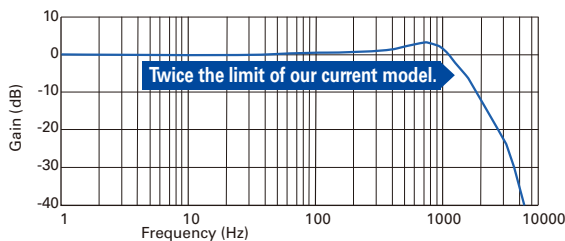

Features Model-based Following Control

Model-based tracking control enables an improved target response curve, enhanced disturbance suppression, and greater robustness.

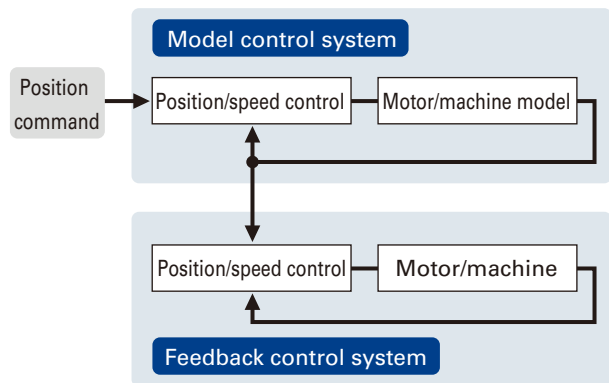

Auto-Tuning

Servo amplifier automatically optimizes servo gain and filter frequency in realtime.

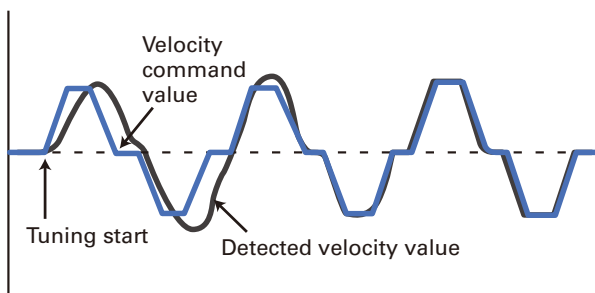

Downsized Servo Motors

R2 Series Servo Motors are downsized as much as 30% in size and 25% in volume from our conventional product, achieving high torque and high performance.

※ Our conventional product is "SANMOTION Q".



Feed-forward vibration suppression control

With feed-forward vibration suppression control, vibrations at the processing point and base of a machine can be suppressed through simple tuning procedures. Vibration control frequencies are selectable.

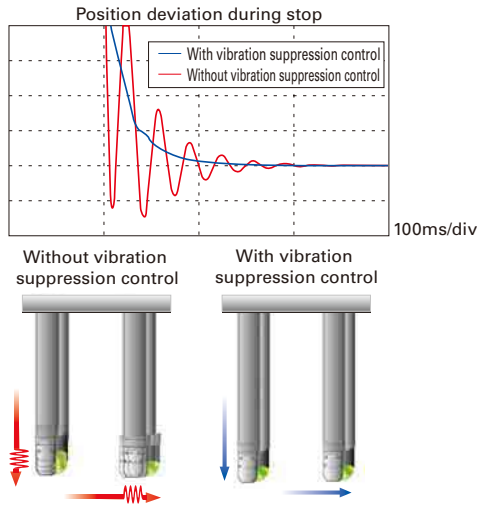

Command Follow-up Control

Performance of the positioning doubled in comparison with current models by adoption of new positioning control algorithm and new speed control algorithm. And position deviation ≈ 0 is achieved.

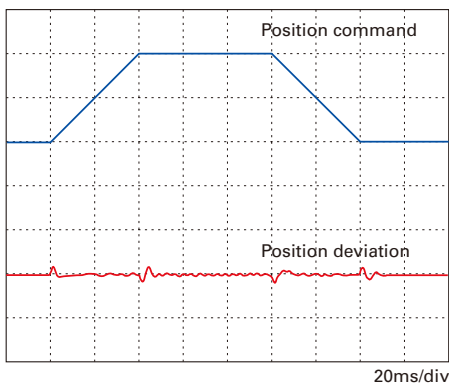

Resonance Suppression

A 4th-order notch filter reduces phase delay to suppress mechanical resonance and improve velocity response of equipment.

Disturbance Suppression

It is possible to control impacts from other axes in case of multiaxial constitution, by using the new disturbance observer with extended applicable frequency.

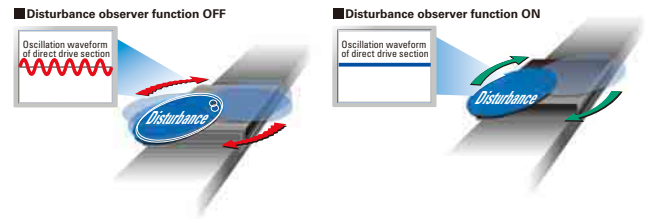

Low Cogging Torque

The R2 Series Servo Motor's low cogging torque delivers smooth rotation that is ideal for high precision processes and vibration-sensitive conveyor applications.

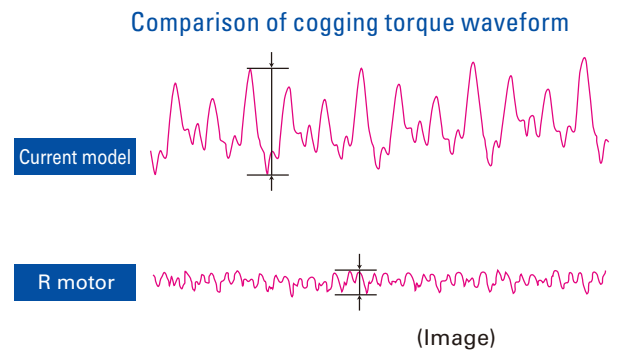

High Resolution

Support for encoders up to 17 bit (131,072 divisions) is available for high resolution control. An optional 20 bit encoder (1,048,576 divisions) is also available.

Now Available with EtherCAT Interface

EtherCAT is a 100Mbps high-speed fieldbus system, which helps shorten Takt time. It is compatible with Ethernet, and its high versatility enables the creation of a system compatible with a variety of devices. Servo amplifier firmware can be updated via EtherCAT. It is also certified through EtherCAT conformance testing conducted by a third party organization.

EtherCAT[®]
Conformance tested



Safety Model newly added to lineup

Since this new model safely shutdown motor torque, safety system is more easily installed on the equipments. This safety function is defined in the "IEC61800-5-2:Safe Torque Off" and "IEC60204-1:Stop Category 0". In addition, this model has acquired "IEC61508, SIL2/IEC62061,SILCL2" and "ISO13849-1:Cat.3,PL=d".



Water Proof and Dust Proof

The protection code for R2 Servo Motor (130mm sq. - 220mm sq.) is IP65, as it is highly waterproof and dustproof; and for all other models, a protection code of IP67 is available.



*Shaft feedthrough and cable end are excluded

All-in-One Control

Configurable parameters allow you to switch between control modes for torque, position or velocity.

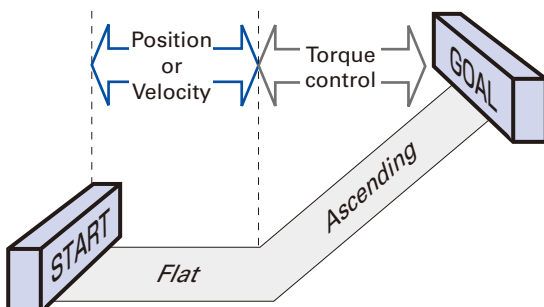

5-digit LED Display, Built-in Operator

The built-in operator allows you to change parameters and monitor the amplifier status and alarm trace.



Test Function (JOG)

On-board JOG operation function is available for testing motor and amplifier connection without the need to connect to host device.



Setup Software

The setup software allows you to set parameters, view graphical displays of monitored position, velocity or torque waveforms.

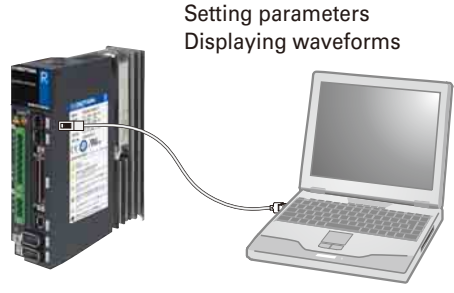

Multiaxial Monitor Function

The setup software allows up to 15 axes to be monitored. To enable monitoring of multiple axes, an optional communication converter and amplifier communication cable are available.

*Analog/Pulse input type only

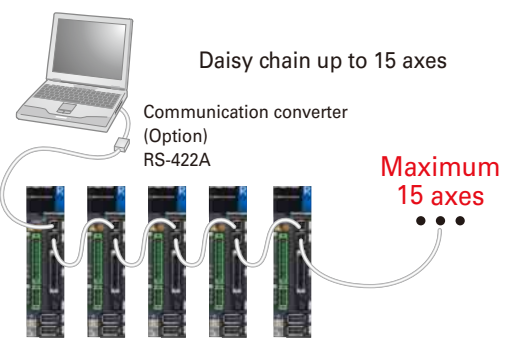

Built-in Regeneration Resistor

It is possible to choose whether to equip regenerative resistance or not. If the regenerative resistance capability is insufficient, it is possible to use an external regenerative resistance unit.

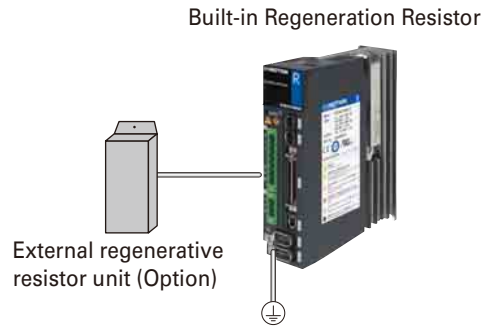

Built-in Dynamic Brake

A built-in dynamic brake provides emergency stop capability. The six kinds of motion sequences for the dynamic brake can be selected by parameter setting.

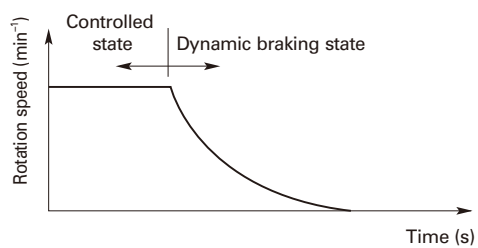

Fully-closed loop control

Fully-closed control is possible using a linear scale mounted on the device together with high resolution encoder information.

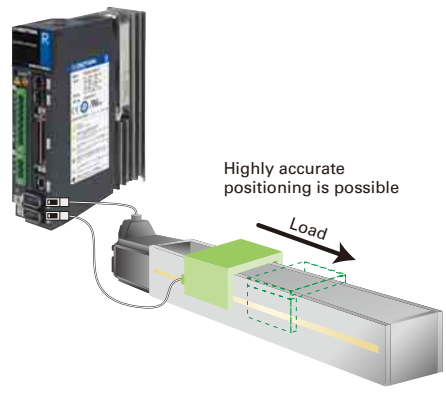

R2 Servo Motor 100V System Small capacity • Medium Inertia

Standard specifications Output shaft: straight, oil seal: none, connection: cable

Rated Output	Motor Flange Size	Protection Code	Holding Brake	CE-UL	Model No.		Page	
					Battery backup method absolute encoder (PA035C)	Absolute encoder for incremental system (PA035S)	Specifications	Dimensions
30W	40mm sq.	IP67	—	—	R2EA04003FXP00	R2EA04003FXH00	P.23	P.44
			—	Standard	R2EA04003FXP00M	R2EA04003FXH00M	P.23	P.44
			yes (DC24V)	—	R2EA04003FCP00	R2EA04003FCH00	P.23	P.44
		IP65	—	Standard	R2EA04003FCP00M	R2EA04003FCH00M	P.23	P.44
			—	—	R2EA04003FXP03	R2EA04003FXH03	P.23	P.44
			yes (DC24V)	—	R2EA04003FCP03	R2EA04003FCH03	P.23	P.44
50W	40mm sq.	IP67	—	—	R2EA04005FXP00	R2EA04005FXH00	P.23	P.44
			—	Standard	R2EA04005FXP00M	R2EA04005FXH00M	P.23	P.44
			yes (DC24V)	—	R2EA04005FCP00	R2EA04005FCH00	P.23	P.44
		IP65	—	Standard	R2EA04005FCP00M	R2EA04005FCH00M	P.23	P.44
			—	—	R2EA04005FXP03	R2EA04005FXH03	P.23	P.44
			yes (DC24V)	—	R2EA04005FCP03	R2EA04005FCH03	P.23	P.44
80W	40mm sq.	IP67	—	—	R2EA04008FXP00	R2EA04008FXH00	P.23	P.44
			—	Standard	R2EA04008FXP00M	R2EA04008FXH00M	P.23	P.44
			yes (DC24V)	—	R2EA04008FCP00	R2EA04008FCH00	P.23	P.44
		IP65	—	Standard	R2EA04008FCP00M	R2EA04008FCH00M	P.23	P.44
			—	—	R2EA04008FXP03	R2EA04008FXH03	P.23	P.44
			yes (DC24V)	—	R2EA04008FCP03	R2EA04008FCH03	P.23	P.44
100W	60mm sq.	IP67	—	—	R2EA06010FXP00	R2EA06010FXH00	P.24	P.44
			—	Standard	R2EA06010FXP00M	R2EA06010FXH00M	P.24	P.44
			yes (DC24V)	—	R2EA06010FCP00	R2EA06010FCH00	P.24	P.44
		IP65	—	Standard	R2EA06010FCP00M	R2EA06010FCH00M	P.24	P.44
			—	—	R2EA06010FXP03	R2EA06010FXH03	P.24	P.44
			yes (DC24V)	—	R2EA06010FCP03	R2EA06010FCH03	P.24	P.44
200W	60mm sq.	IP67	—	—	R2EA06020FXP00	R2EA06020FXH00	P.24	P.44
			—	Standard	R2EA06020FXP00M	R2EA06020FXH00M	P.24	P.44
			yes (DC24V)	—	R2EA06020FCP00	R2EA06020FCH00	P.24	P.44
		IP65	—	Standard	R2EA06020FCP00M	R2EA06020FCH00M	P.24	P.44
			—	—	R2EA06020FXP03	R2EA06020FXH03	P.24	P.44
			yes (DC24V)	—	R2EA06020FCP03	R2EA06020FCH03	P.24	P.44

*For specifications on other model, please contact us.

Servo Amplifier 100V System

Type	Main Power	Control Power	Encoder Type	Selectable Output	Internal Registration Resistor	Safe Torque Off function	Amplifier Capacity	Model No.	Page		
									Servo Amplifier Specifications	Dimensions	
Analog/Pulse input type	AC100V System AC100 to 115V Single-phase	AC100V System AC100 to 115V Single-phase	Serial encoder	NPN	—	—	15A	RS2E01A0AL0	P.21	P.51	
							30A	RS2E03A0AL0	P.21	P.51	
							With	15A	RS2E01A0AA0	P.21	P.51
				PNP			30A	RS2E03A0AA0	P.21	P.51	
							—	15A	RS2E01A0BL0	P.21	P.51
							With	30A	RS2E03A0BL0	P.21	P.51
EtherCAT interface type	AC100V System AC100 to 115V Single-phase	AC100V System AC100 to 115V Single-phase	Serial encoder	Photo relay output	—	With (with delay circuit)	15A	RS2E01A0KL4	P.21	P.51	
							30A	RS2E03A0KL4	P.21	P.51	
							With	15A	RS2E01A0KA4	P.21	P.51
							30A	RS2E03A0KA4	P.21	P.51	

*Our standard servo amplifier has attained the UL, c-UL and EN Standards.
*For specifications on other model, please contact us.

R2 Servo Motor 200V System Small capacity • Medium Inertia

Standard specifications Output shaft: straight, oil seal: none, connection: cable

Rated Output	Motor Flange Size	Protection Code	Holding Brake	CE-UL	Model No.		Page		
					Battery backup method absolute encoder (PA035C)	Absolute encoder for incremental system (PA035S)	Specifications	Dimensions	
30W	40mm sq.	IP67	—	—	R2AA04003FXP00	R2AA04003FXH00	P.25	P.44	
			Standard	R2AA04003FXP00M	R2AA04003FXH00M	P.25	P.44		
			yes (DC24V)	—	R2AA04003FCP00	R2AA04003FCH00	P.25	P.44	
		IP65	—	—	R2AA04003FCP00M	R2AA04003FCH00M	P.25	P.44	
			Standard	R2AA04003FXP03	R2AA04003FXH03	P.25	P.44		
			yes (DC24V)	—	R2AA04003FCP03	R2AA04003FCH03	P.25	P.44	
50W	40mm sq.	IP67	—	—	R2AA04005FXP00	R2AA04005FXH00	P.25	P.44	
			Standard	R2AA04005FXP00M	R2AA04005FXH00M	P.25	P.44		
			yes (DC24V)	—	R2AA04005FCP00	R2AA04005FCH00	P.25	P.44	
		IP65	—	—	R2AA04005FCP00M	R2AA04005FCH00M	P.25	P.44	
			Standard	R2AA04005FXP03	R2AA04005FXH03	P.25	P.44		
			yes (DC24V)	—	R2AA04005FCP03	R2AA04005FCH03	P.25	P.44	
100W	40mm sq.	IP67	—	—	R2AA04010FXP00	R2AA04010FXH00	P.25	P.44	
			Standard	R2AA04010FXP00M	R2AA04010FXH00M	P.25	P.44		
			yes (DC24V)	—	R2AA04010FCP006 ^(note)	R2AA04010FCH006 ^(note)	P.25	P.44	
		IP65	—	—	R2AA04010FCP00M6 ^(note)	R2AA04010FCH00M6 ^(note)	P.25	P.44	
			Standard	R2AA04010FXP03	R2AA04010FXH03	P.25	P.44		
			yes (DC24V)	—	R2AA04010FCP036 ^(note)	R2AA04010FCH036 ^(note)	P.25	P.44	
	60mm sq.	IP67	—	—	R2AA06010FXP00	R2AA06010FXH00	P.25	P.44	
			Standard	R2AA06010FXP00M	R2AA06010FXH00M	P.25	P.44		
			yes (DC24V)	—	R2AA06010FCP00	R2AA06010FCH00	P.25	P.44	
		IP65	—	—	R2AA06010FCP00M	R2AA06010FCH00M	P.25	P.44	
			Standard	R2AA06010FXP03	R2AA06010FXH03	P.25	P.44		
			yes (DC24V)	—	R2AA06010FCP03M6 ^(note)	R2AA06010FCH03M6 ^(note)	P.25	P.44	
200W	60mm sq.	IP67	—	—	R2AA06020FXP00	R2AA06020FXH00	P.26	P.44	
			Standard	R2AA06020FXP00M	R2AA06020FXH00M	P.26	P.44		
			yes (DC24V)	—	R2AA06020FCP00	R2AA06020FCH00	P.26	P.44	
		IP65	—	—	R2AA06020FCP00M	R2AA06020FCH00M	P.26	P.44	
			Standard	R2AA06020FXP03	R2AA06020FXH03	P.26	P.44		
			yes (DC24V)	—	R2AA06020FCP03	R2AA06020FCH03	P.26	P.44	
	80mm sq.	IP67	—	—	R2AA08020FXP00	R2AA08020FXH00	P.26	P.44	
			Standard	R2AA08020FXP00M	R2AA08020FXH00M	P.26	P.44		
			yes (DC24V)	—	R2AA08020FCP00	R2AA08020FCH00	P.26	P.44	
		IP65	—	—	R2AA08020FCP00M	R2AA08020FCH00M	P.26	P.44	
			Standard	R2AA08020FXP03	R2AA08020FXH03	P.26	P.44		
			yes (DC24V)	—	R2AA08020FCP03M6 ^(note)	R2AA08020FCH03M6 ^(note)	P.26	P.44	
400W	60mm sq.	IP67	—	—	R2AA06040FXP00	R2AA06040FXH00	P.26	P.44	
			Standard	R2AA06040FXP00M	R2AA06040FXH00M	P.26	P.44		
			yes (DC24V)	—	R2AA06040FCP006 ^(note)	R2AA06040FCH006 ^(note)	P.26	P.44	
			Standard	R2AA06040FCP00M6 ^(note)	R2AA06040FCH00M6 ^(note)	P.26	P.44		
			—	—	R2AA06040HXP00	R2AA06040HXH00	P.26	P.44	
			Standard	R2AA06040HXP00M	R2AA06040HXH00M	P.26	P.44		
		IP65	yes (DC24V)	—	—	R2AA06040HCP006 ^(note)	R2AA06040HCH006 ^(note)	P.26	P.44
			Standard	R2AA06040HCP00M6 ^(note)	R2AA06040HCH00M6 ^(note)	P.26	P.44		
			—	—	R2AA06040FXP03	R2AA06040FXH03	P.26	P.44	
			Standard	R2AA06040FXP03M	R2AA06040FXH03M	P.26	P.44		
			yes (DC24V)	—	R2AA06040FCP036 ^(note)	R2AA06040FCH036 ^(note)	P.26	P.44	
			Standard	R2AA06040FCP03M6 ^(note)	R2AA06040FCH03M6 ^(note)	P.26	P.44		

For models with (note), please use with the reduction rating. The reduction rating would be 90% of the rated output in the table.
 * For specifications of models other than listed, please contact us.

Features and Functions
 Model No. List • Model Number Nomenclature
 System Configuration
 Standard Specifications
 Encoder Wiring Diagram
 External Wiring Diagram
 Dimensions
 Setup Software
 Option

R2 Servo Motor 200V System Small capacity・Medium Inertia

Standard specifications Output shaft: straight, oil seal: none, connection: cable

Rated Output	Motor Flange Size	Protection Code	Holding Brake	CE-UL	Model No.		Page			
					Battery backup method absolute encoder (PA035C)	Absolute encoder for incremental system (PA035S)	Specifications	Dimensions		
400W	80mm sq.	IP67	—	—	R2AA08040FXP00	R2AA08040FXH00	P.27	P.44		
			Standard	R2AA08040FXP00M	R2AA08040FXH00M	P.27	P.44			
			yes (DC24V)	—	R2AA08040FCP00	R2AA08040FCH00	P.27	P.44		
		IP65	—	—	R2AA08040FXP03	R2AA08040FXH03	P.27	P.44		
			Standard	R2AA08040FXP03M	R2AA08040FXH03M	P.27	P.44			
			yes (DC24V)	—	R2AA08040FCP03	R2AA08040FCH03	P.27	P.44		
	750W	80mm sq.	IP67	—	—	R2AA08075FXP00	R2AA08075FXH00	P.27	P.44	
				Standard	R2AA08075FXP00M	R2AA08075FXH00M	P.27	P.44		
				yes (DC24V)	—	R2AA08075FCP00	R2AA08075FCH00	P.27	P.44	
			IP65	—	—	R2AA08075FXP03	R2AA08075FXH03	P.27	P.44	
				Standard	R2AA08075FXP03M	R2AA08075FXH03M	P.27	P.44		
				yes (DC24V)	—	R2AA08075FCP03	R2AA08075FCH03	P.27	P.44	
86mm sq.			IP67	—	—	R2AAB8075FXP00	R2AAB8075FXH00	P.28	P.44	
				Standard	R2AAB8075FXP00M	R2AAB8075FXH00M	P.28	P.44		
				yes (DC24V)	—	R2AAB8075FCP00	R2AAB8075FCH00	P.28	P.44	
			IP65	—	—	R2AAB8075FXP03	R2AAB8075FXH03	P.28	P.44	
				Standard	R2AAB8075FXP03M	R2AAB8075FXH03M	P.28	P.44		
				yes (DC24V)	—	R2AAB8075FCP03	R2AAB8075FCH03	P.28	P.44	
		100mm sq.	IP67	—	—	R2AA10075FXP00	R2AA10075FXH00	P.27	P.44	
				Standard	R2AA10075FXP00M	R2AA10075FXH00M	P.27	P.44		
				yes (DC24V)	—	R2AA10075FCP00	R2AA10075FCH00	P.27	P.44	
			IP65	—	—	R2AA10075FXP03	R2AA10075FXH03	P.27	P.44	
				Standard	R2AA10075FXP03M	R2AA10075FXH03M	P.27	P.44		
				yes (DC24V)	—	R2AA10075FCP03	R2AA10075FCH03	P.27	P.44	
1kW			86mm sq.	IP67	—	—	R2AAB8100FXP00	R2AAB8100FXH00	P.28	P.44
					Standard	R2AAB8100FXP00M	R2AAB8100FXH00M	P.28	P.44	
					yes (DC24V)	—	R2AAB8100FCP00	R2AAB8100FCH00	P.28	P.44
				IP65	—	—	R2AAB8100FXP03	R2AAB8100FXH03	P.28	P.44
					Standard	R2AAB8100FXP03M	R2AAB8100FXH03M	P.28	P.44	
					yes (DC24V)	—	R2AAB8100FCP03	R2AAB8100FCH03	P.28	P.44
	100mm sq.	IP67		—	—	R2AAB8100HXP00	R2AAB8100HXH00	P.27	P.44	
				Standard	R2AAB8100HXP00M	R2AAB8100HXH00M	P.27	P.44		
				yes (DC24V)	—	R2AAB8100HCP00	R2AAB8100HCH00	P.27	P.44	
		IP65		—	—	R2AAB8100HXP03	R2AAB8100HXH03	P.27	P.44	
				Standard	R2AAB8100HXP03M	R2AAB8100HXH03M	P.27	P.44		
				yes (DC24V)	—	R2AAB8100HCP03	R2AAB8100HCH03	P.27	P.44	
		100mm sq.	IP67	—	—	R2AA10100FXP00	R2AA10100FXH00	P.29	P.44	
				Standard	R2AA10100FXP00M	R2AA10100FXH00M	P.29	P.44		
				yes (DC24V)	—	R2AA10100FCP00	R2AA10100FCH00	P.29	P.44	
			IP65	—	—	R2AA10100FXP03	R2AA10100FXH03	P.29	P.44	
				Standard	R2AA10100FXP03M	R2AA10100FXH03M	P.29	P.44		
				yes (DC24V)	—	R2AA10100FCP03	R2AA10100FCH03	P.29	P.44	

※For specifications on other model, please contact us.

R2 Servo Motor 200V System Medium capacity • Medium Inertia

Standard specifications Output shaft: with key, oil seal: yes, connection: canon plug

Rated Output	Motor Flange Size	Protection Code	Holding Brake	CE-UL	Model No.		Page	
					Battery backup method absolute encoder (PA035C)	Absolute encoder for incremental system (PA035S)	Specifications	Dimensions
550W	130mm sq.	IP65	—	—	R2AA13050HXP00	R2AA13050HXH00	P.28	P.45
				Standard	R2AA13050HXP00M	R2AA13050HXH00M	P.28	P.45
			yes (DC24V)	—	R2AA13050HCP00	R2AA13050HCH00	P.28	P.45
				Standard	R2AA13050HCP00M	R2AA13050HCH00M	P.28	P.45
			—	—	R2AA13050DXP00	R2AA13050DXH00	P.28	P.45
				Standard	R2AA13050DXP00M	R2AA13050DXH00M	P.28	P.45
yes (DC24V)	—	R2AA13050DCP00	R2AA13050DCH00	P.28	P.45			
	Standard	R2AA13050DCP00M	R2AA13050DCH00M	P.28	P.45			
1.2kW	130mm sq.	IP65	—	—	R2AA13120BXP00	R2AA13120BXH00	P.28	P.45
				Standard	R2AA13120BXP00M	R2AA13120BXH00M	P.28	P.45
			yes (DC24V)	—	R2AA13120BCP00	R2AA13120BCH00	P.28	P.45
				Standard	R2AA13120BCP00M	R2AA13120BCH00M	P.28	P.45
			—	—	R2AA13120LXP00	R2AA13120LXH00	P.29	P.45
				Standard	R2AA13120LXP00M	R2AA13120LXH00M	P.29	P.45
			yes (DC24V)	—	R2AA13120LCP00	R2AA13120LCH00	P.29	P.45
				Standard	R2AA13120LCP00M	R2AA13120LCH00M	P.29	P.45
			—	—	R2AA13120DXP00	R2AA13120DXH00	P.29	P.45
				Standard	R2AA13120DXP00M	R2AA13120DXH00M	P.29	P.45
			yes (DC24V)	—	R2AA13120DCP00	R2AA13120DCH00	P.29	P.45
				Standard	R2AA13120DCP00M	R2AA13120DCH00M	P.29	P.45
1.8kW	130mm sq.	IP65	—	—	R2AA13180HXP00	R2AA13180HXH00	P.29	P.45
				Standard	R2AA13180HXP00M	R2AA13180HXH00M	P.29	P.45
			yes(DC24V)	—	R2AA13180HCP00	R2AA13180HCH00	P.29	P.45
				Standard	R2AA13180HCP00M	R2AA13180HCH00M	P.29	P.45
			—	—	R2AA13180DXP00	R2AA13180DXH00	P.30	P.45
				Standard	R2AA13180DXP00M	R2AA13180DXH00M	P.30	P.45
yes(DC24V)	—	R2AA13180DCP00	R2AA13180DCH00	P.30	P.45			
	Standard	R2AA13180DCP00M	R2AA13180DCH00M	P.30	P.45			
2kW	130mm sq.	IP65	—	—	R2AA13200LXP00	R2AA13200LXH00	P.30	P.45
				Standard	R2AA13200LXP00M	R2AA13200LXH00M	P.30	P.45
			yes (DC24V)	—	R2AA13200LCP00	R2AA13200LCH00	P.30	P.45
				Standard	R2AA13200LCP00M	R2AA13200LCH00M	P.30	P.45
			—	—	R2AA13200DXP00	R2AA13200DXH00	P.30	P.45
				Standard	R2AA13200DXP00M	R2AA13200DXH00M	P.30	P.45
yes (DC24V)	—	R2AA13200DCP00	R2AA13200DCH00	P.30	P.45			
	Standard	R2AA13200DCP00M	R2AA13200DCH00M	P.30	P.45			
3.5kW	180mm sq.	IP65	—	—	R2AA18350LXP00	R2AA18350LXH00	P.30	P.46
				Standard	R2AA18350LXP00M	R2AA18350LXH00M	P.30	P.46
			yes(DC24V)	—	R2AA18350LCP00	R2AA18350LCH00	P.30	P.46
				Standard	R2AA18350LCP00M	R2AA18350LCH00M	P.30	P.46
	—	—	R2AA18350DXP00	R2AA18350DXH00	P.31	P.46		
		Standard	R2AA18350DXP00M	R2AA18350DXH00M	P.31	P.46		
		yes(DC24V)	—	R2AA18350DCP00	R2AA18350DCH00	P.31	P.46	
			Standard	R2AA18350DCP00M	R2AA18350DCH00M	P.31	P.46	
220mm sq.	IP65	—	—	R2AA22350LXP00	R2AA22350LXH00	P.31	P.47	
			Standard	R2AA22350LXP00M	R2AA22350LXH00M	P.31	P.47	
		yes (DC24V)	—	R2AA22350LCP00	R2AA22350LCH00	P.31	P.47	
			Standard	R2AA22350LCP00M	R2AA22350LCH00M	P.31	P.47	
4.5kW	180mm sq.	IP65	—	—	R2AA18450HXP00	R2AA18450HXH00	P.31	P.46
				Standard	R2AA18450HXP00M	R2AA18450HXH00M	P.31	P.46
			yes(DC24V)	—	R2AA18450HCP00	R2AA18450HCH00	P.31	P.46
				Standard	R2AA18450HCP00M	R2AA18450HCH00M	P.31	P.46
5kW	220mm sq.	IP65	—	—	R2AA22500LXP00	R2AA22500LXH00	P.32	P.47
				Standard	R2AA22500LXP00M	R2AA22500LXH00M	P.32	P.47
			yes (DC24V)	—	R2AA22500LCP00	R2AA22500LCH00	P.32	P.47
				Standard	R2AA22500LCP00M	R2AA22500LCH00M	P.32	P.47

※For specifications on other model, please contact us.

Features and Functions

Model No. List • Model Number Nomenclature

System Configuration

Standard Specifications

Encoder Wiring Diagram

External Wiring Diagram

Dimensions

Setup Software

Option

R2 Servo Motor 200V System Medium capacity • Medium Inertia

Standard specifications Output shaft: with key, oil seal: yes, connection: canon plug

Rated Output	Motor Flange Size	Protection Code	Holding Brake	CE-UL	Model No.		Page	
					Battery backup method absolute encoder (PA035C)	Absolute encoder for incremental system (PA035S)	Specifications	Dimensions
5.5kW	180mm sq.	IP65	—	—	R2AA18550RXP00	R2AA18550RXH00	P.31	P.46
				Standard	R2AA18550RXP00M	R2AA18550RXH00M	P.31	P.46
			yes(DC24V)	—	R2AA18550RCP00	R2AA18550RCH00	P.31	P.46
				Standard	R2AA18550RCP00M	R2AA18550RCH00M	P.31	P.46
			—	—	R2AA18550HXP00	R2AA18550HXH00	P.32	P.46
				Standard	R2AA18550HXP00M	R2AA18550HXH00M	P.32	P.46
yes(DC24V)	—	R2AA18550HCP00	R2AA18550HCH00	P.32	P.46			
	Standard	R2AA18550HCP00M	R2AA18550HCH00M	P.32	P.46			
7.5kW	180mm sq.	IP65	—	—	R2AA18750HXP00	R2AA18750HXH00	P.32	P.46
				Standard	R2AA18750HXP00M	R2AA18750HXH00M	P.32	P.46
			yes(DC24V)	—	R2AA18750HCP00	R2AA18750HCH00	P.32	P.46
				Standard	R2AA18750HCP00M	R2AA18750HCH00M	P.32	P.46
11kW	180mm sq.	IP65 (Excluding cooling fan)	—	—	R2AA1811KRX00	R2AA1811KRXH00	P.32	P.46
				Standard	R2AA1811KRX00M	R2AA1811KRXH00M	P.32	P.46
			yes(DC24V)	—	R2AA1811KRCP00	R2AA1811KRCH00	P.32	P.46
				Standard	R2AA1811KRCP00M	R2AA1811KRCH00M	P.32	P.46

※For specifications on other model, please contact us.

Q2 Servo Motor 200V System Medium capacity • Medium Inertia

Standard specifications Output shaft: with key, oil seal: yes, connection: canon plug

Rated Output	Motor Flange Size	Protection Code	Holding Brake	CE-UL	Model No.			Page	
					Battery backup method absolute encoder (PA035C)	Resolver method batteryless absolute encoder (RA035C)	Wire-saving incremental encoder (PP031T/PP038H/PP062)	Specifications	Dimensions
2kW	180mm sq.	IP67	—	—	Q2AA18200HXP00	Q2AA18200HXW00	Q2AA18200HXS00	P.33	P.49
				Standard	Q2AA18200HXP00M	Q2AA18200HXW00M	Q2AA18200HXS00M	P.33	P.49
			yes (DC24V)	—	Q2AA18200HCP00	Q2AA18200HCW00	Q2AA18200HCS00	P.33	P.49
				Standard	Q2AA18200HCP00M	Q2AA18200HCW00M	Q2AA18200HCS00M	P.33	P.49
5.5kW	220mm sq.	IP67	—	—	Q2AA22550BXP00	Q2AA22550BXW00	Q2AA22550BXS00	P.33	P.49
				Standard	Q2AA22550BXP00M	Q2AA22550BXW00M	Q2AA22550BXS00M	P.33	P.49
			yes (DC24V)	—	Q2AA22550BCP00	Q2AA22550BCW00	Q2AA22550BCS00	P.33	P.49
				Standard	Q2AA22550BCP00M	Q2AA22550BCW00M	Q2AA22550BCS00M	P.33	P.49
7kW	220mm sq.	IP67	—	—	Q2AA22700SXP00	Q2AA22700SXW00	Q2AA22700SXS00	P.33	P.49
				Standard	Q2AA22700SXP00M	Q2AA22700SXW00M	Q2AA22700SXS00M	P.33	P.49
			yes (DC24V)	—	Q2AA22700SCP00	Q2AA22700SCW00	Q2AA22700SCS00	P.33	P.49
				Standard	Q2AA22700SCP00M	Q2AA22700SCW00M	Q2AA22700SCS00M	P.33	P.49
11kW	220mm sq.	IP67	—	—	Q2AA2211KVP00	Q2AA2211KVXW00	Q2AA2211KVXS00	P.34	P.49
				Standard	Q2AA2211KVP00M	Q2AA2211KVXW00M	Q2AA2211KVXS00M	P.34	P.49
			yes (DC24V)	—	Q2AA2211KVC00	Q2AA2211KVCW00	Q2AA2211KVCS00	P.34	P.49
				Standard	Q2AA2211KVC00M	Q2AA2211KVCW00M	Q2AA2211KVCS00M	P.34	P.49
15kW	220mm sq.	IP67	—	—	Q2AA2215KVP00	Q2AA2215KVXW00	Q2AA2215KVXS00	P.34	P.49
				Standard	Q2AA2215KVP00M	Q2AA2215KVXW00M	Q2AA2215KVXS00M	P.34	P.49
			yes (DC24V)	—	Q2AA2215KVC00	Q2AA2215KVCW00	Q2AA2215KVCS00	P.34	P.49
				Standard	Q2AA2215KVC00M	Q2AA2215KVCW00M	Q2AA2215KVCS00M	P.34	P.49

※For specifications on other model, please contact us.

R1 Servo Motor 200V System Medium capacity • Low inertia

Standard specifications Output shaft: with key, oil seal: yes, connection: canon plug

Rated Output	Motor Flange Size	Protection Code	Holding Brake	CE-UL	Model No.			Page	
					Battery backup method absolute encoder (PA035C)	Resolver method batteryless absolute encoder (RA035C)	Wire-saving incremental encoder (PP031T/PP038H/PP062)	Specifications	Dimensions
5.5kW	180mm sq.	IP65 (Excluding cooling fan)	—	—	R1AA18550HXP00	R1AA18550HXW00	R1AA18550HXS00	P.35	P.48
			yes (DC24V)	—	R1AA18550HCP00	R1AA18550HCW00	R1AA18550HCS00	P.35	P.48
7.5kW	180mm sq.		—	—	R1AA18750HXP00	R1AA18750HXW00	R1AA18750HXS00	P.35	P.48
			yes (DC24V)	—	R1AA18750HCP00	R1AA18750HCW00	R1AA18750HCS00	P.35	P.48
11kW	180mm sq.		—	—	R1AA1811KRX00	R1AA1811KRXW00	R1AA1811KRXS00	P.36	P.48
			yes (DC24V)	—	R1AA1811KRCP00	R1AA1811KRCW00	R1AA1811KRCS00	P.36	P.48
15kW	180mm sq.		—	—	R1AA1815KBX00	R1AA1815KBXW00	R1AA1815KBXS00	P.36	P.48
			yes (DC24V)	—	R1AA1815KB00	R1AA1815KB0W00	R1AA1815KB0S00	P.36	P.48

※For specifications on other model, please contact us.

Features and Functions

Model No. List • Model Number Nomenclature

System Configuration

Standard Specifications

Encoder Wiring Diagram

External Wiring Diagram

Dimensions

Setup Software

Option

Q1 Servo Motor 200V System Medium capacity • Low Inertia

Standard specifications Output shaft: with key, oil seal: yes, connection: canon plug

Rated Output	Motor Flange Size	Protection Code	Holding Brake	CE-UL	Model No.			Page		
					Battery backup method absolute encoder (PA035C)	Resolver method batteryless absolute encoder (RA035C)	Wire-saving incremental encoder (PP031T/PP038H/PP062)	Specifications	Dimensions	
1kW	100mm sq.	IP67	—	—	Q1AA10100DXP00	Q1AA10100DXW00	Q1AA10100DXS00	P.37	P.49	
				Standard	Q1AA10100DXP00M	Q1AA10100DXW00M	Q1AA10100DXS00M	P.37	P.49	
			yes (DC24V)	—	Q1AA10100DCP00	Q1AA10100DCW00	Q1AA10100DCS00	P.37	P.49	
	Standard	Q1AA10100DCP00M		Q1AA10100DCW00M	Q1AA10100DCS00M	P.37	P.49			
	—	Q1AA12100DXP00		Q1AA12100DXW00	Q1AA12100DXS00	P.38	P.49			
	120mm sq.	IP67	—	Standard	Q1AA12100DXP00M	Q1AA12100DXW00M	Q1AA12100DXS00M	P.38	P.49	
—				Q1AA12100DCP00	Q1AA12100DCW00	Q1AA12100DCS00	P.38	P.49		
yes (DC24V)			Standard	Q1AA12100DCP00M	Q1AA12100DCW00M	Q1AA12100DCS00M	P.38	P.49		
	1.5kW	100mm sq.	IP67	—	—	Q1AA10150DXP00	Q1AA10150DXW00	Q1AA10150DXS00	P.37	P.49
					Standard	Q1AA10150DXP00M	Q1AA10150DXW00M	Q1AA10150DXS00M	P.37	P.49
yes (DC24V)				—	Q1AA10150DCP00	Q1AA10150DCW00	Q1AA10150DCS00	P.37	P.49	
		Standard	Q1AA10150DCP00M	Q1AA10150DCW00M	Q1AA10150DCS00M	P.37	P.49			
		2kW	100mm sq.	IP67	—	—	Q1AA10200DXP00	Q1AA10200DXW00	Q1AA10200DXS00	P.37
Standard						Q1AA10200DXP00M	Q1AA10200DXW00M	Q1AA10200DXS00M	P.37	P.49
yes (DC24V)	—				Q1AA10200DCP00	Q1AA10200DCW00	Q1AA10200DCS00	P.37	P.49	
	Standard		Q1AA10200DCP00M	Q1AA10200DCW00M	Q1AA10200DCS00M	P.37	P.49			
	120mm sq.		IP67	—	—	Q1AA12200DXP00	Q1AA12200DXW00	Q1AA12200DXS00	P.38	P.49
Standard					Q1AA12200DXP00M	Q1AA12200DXW00M	Q1AA12200DXS00M	P.38	P.49	
yes (DC24V)		—		Q1AA12200DCP00	Q1AA12200DCW00	Q1AA12200DCS00	P.38	P.49		
		Standard	Q1AA12200DCP00M	Q1AA12200DCW00M	Q1AA12200DCS00M	P.38	P.49			
		2.5kW	100mm sq.	IP67	—	—	Q1AA10250DXP00	Q1AA10250DXW00	Q1AA10250DXS00	P.38
Standard						Q1AA10250DXP00M	Q1AA10250DXW00M	Q1AA10250DXS00M	P.38	P.49
yes (DC24V)	—				Q1AA10250DCP00	Q1AA10250DCW00	Q1AA10250DCS00	P.38	P.49	
	Standard		Q1AA10250DCP00M	Q1AA10250DCW00M	Q1AA10250DCS00M	P.38	P.49			
	3kW		120mm sq.	IP67	—	—	Q1AA12300DXP00	Q1AA12300DXW00	Q1AA12300DXS00	P.39
Standard						Q1AA12300DXP00M	Q1AA12300DXW00M	Q1AA12300DXS00M	P.39	P.49
yes (DC24V)		—			Q1AA12300DCP00	Q1AA12300DCW00	Q1AA12300DCS00	P.39	P.49	
		Standard	Q1AA12300DCP00M	Q1AA12300DCW00M	Q1AA12300DCS00M	P.39	P.49			
		130mm sq.	IP67	—	—	Q1AA13300DXP00	Q1AA13300DXW00	Q1AA13300DXS00	P.39	P.49
Standard					Q1AA13300DXP00M	Q1AA13300DXW00M	Q1AA13300DXS00M	P.39	P.49	
yes (DC24V)	—			Q1AA13300DCP00	Q1AA13300DCW00	Q1AA13300DCS00	P.39	P.49		
	Standard	Q1AA13300DCP00M	Q1AA13300DCW00M	Q1AA13300DCS00M	P.39	P.49				
	4kW	130mm sq.	IP67	—	—	Q1AA13400DXP00	Q1AA13400DXW00	Q1AA13400DXS00	P.40	P.49
Standard					Q1AA13400DXP00M	Q1AA13400DXW00M	Q1AA13400DXS00M	P.40	P.49	
yes (DC24V)				—	Q1AA13400DCP00	Q1AA13400DCW00	Q1AA13400DCS00	P.40	P.49	
		Standard	Q1AA13400DCP00M	Q1AA13400DCW00M	Q1AA13400DCS00M	P.40	P.49			
		5kW	130mm sq.	IP67	—	—	Q1AA13500DXP00	Q1AA13500DXW00	Q1AA13500DXS00	P.40
Standard						Q1AA13500DXP00M	Q1AA13500DXW00M	Q1AA13500DXS00M	P.40	P.49
yes (DC24V)	—				Q1AA13500DCP00	Q1AA13500DCW00	Q1AA13500DCS00	P.40	P.49	
	Standard	Q1AA13500DCP00M	Q1AA13500DCW00M	Q1AA13500DCS00M	P.40	P.49				

※For specifications on other model, please contact us.

Servo Amplifier 200V System

Type	Main Power	Control Power	Encoder Type	Selectable Output	Internal Registration Resistor	Safe Torque Off function	Amplifier Capacity	Model No.	Page		
									Servo Amplifier Specifications	Dimensions	
Analog / Pulse input type	AC200V system AC200 to 230V 3-phase	AC200V system AC200 to 230V Single-phase	Serial encoder	NPN	—	—	15A	RS2A01A0AL0	P.21	P.51	
							30A	RS2A03A0AL0	P.21	P.51	
							50A	RS2A05A0AL0	P.21	P.51	
							100A	RS2A10A0AL0	P.21	P.52	
							150A	RS2A15A0AL0	P.21	P.52	
							300A	RS2A30A0AL0	P.21	P.52	
							15A	RS2A01A0AA0	P.21	P.51	
							30A	RS2A03A0AA0	P.21	P.51	
							50A	RS2A05A0AA0	P.21	P.51	
				100A	RS2A10A0AA0	P.21	P.52				
				150A	RS2A15A0AA0	P.21	P.52				
				PNP	—	—	15A	RS2A01A0BL0	P.21	P.51	
							30A	RS2A03A0BL0	P.21	P.51	
							50A	RS2A05A0BL0	P.21	P.51	
							100A	RS2A10A0BL0	P.21	P.52	
							150A	RS2A15A0BL0	P.21	P.52	
							300A	RS2A30A0BL0	P.21	P.52	
							15A	RS2A01A0BA0	P.21	P.51	
30A	RS2A03A0BA0	P.21	P.51								
50A	RS2A05A0BA0	P.21	P.51								
100A	RS2A10A0BA0	P.21	P.52								
150A	RS2A15A0BA0	P.21	P.52								
EtherCAT interface type	AC200V system AC200 to 230V 3-phase	AC200V system AC200 to 230V Single-phase	Serial encoder	Photo relay output	—	yes (with delay circuit)	15A	RS2A01A0KL4	P.21	P.51	
							30A	RS2A03A0KL4	P.21	P.51	
							50A	RS2A05A0KL4	P.21	P.51	
							100A	RS2A10A0KL4	P.21	P.52	
							150A	RS2A15A0KL4	P.21	P.52	
							300A	RS2A30A0KL4	P.21	P.52	
							15A	RS2A01A0KA4	P.21	P.51	
							30A	RS2A03A0KA4	P.21	P.51	
							50A	RS2A05A0KA4	P.21	P.51	
							100A	RS2A10A0KA4	P.21	P.52	
							150A	RS2A15A0KA4	P.21	P.52	
							with	15A	RS2A01A0KA4	P.21	P.51
							30A	RS2A03A0KA4	P.21	P.51	
							50A	RS2A05A0KA4	P.21	P.51	
							100A	RS2A10A0KA4	P.21	P.52	
150A	RS2A15A0KA4	P.21	P.52								

※Our standard servo amplifier has attained the UL, c-UL and EN Standards.
 ※For specifications on other model, please contact us.

Features and Functions

Model No. List · Model Number Nomenclature

System Configuration

Standard Specifications

Encoder Wiring Diagram

External Wiring Diagram

Dimensions

Setup Software

Option

Servo Motor

Example: R2 series servo motor models, 60mm sq. flange size, 200W rated output, 6000min⁻¹ maximum rotation speed, DC24V brake, and an batteryless absolute encoder (131072 partition number/rotation), UL/CE approval.

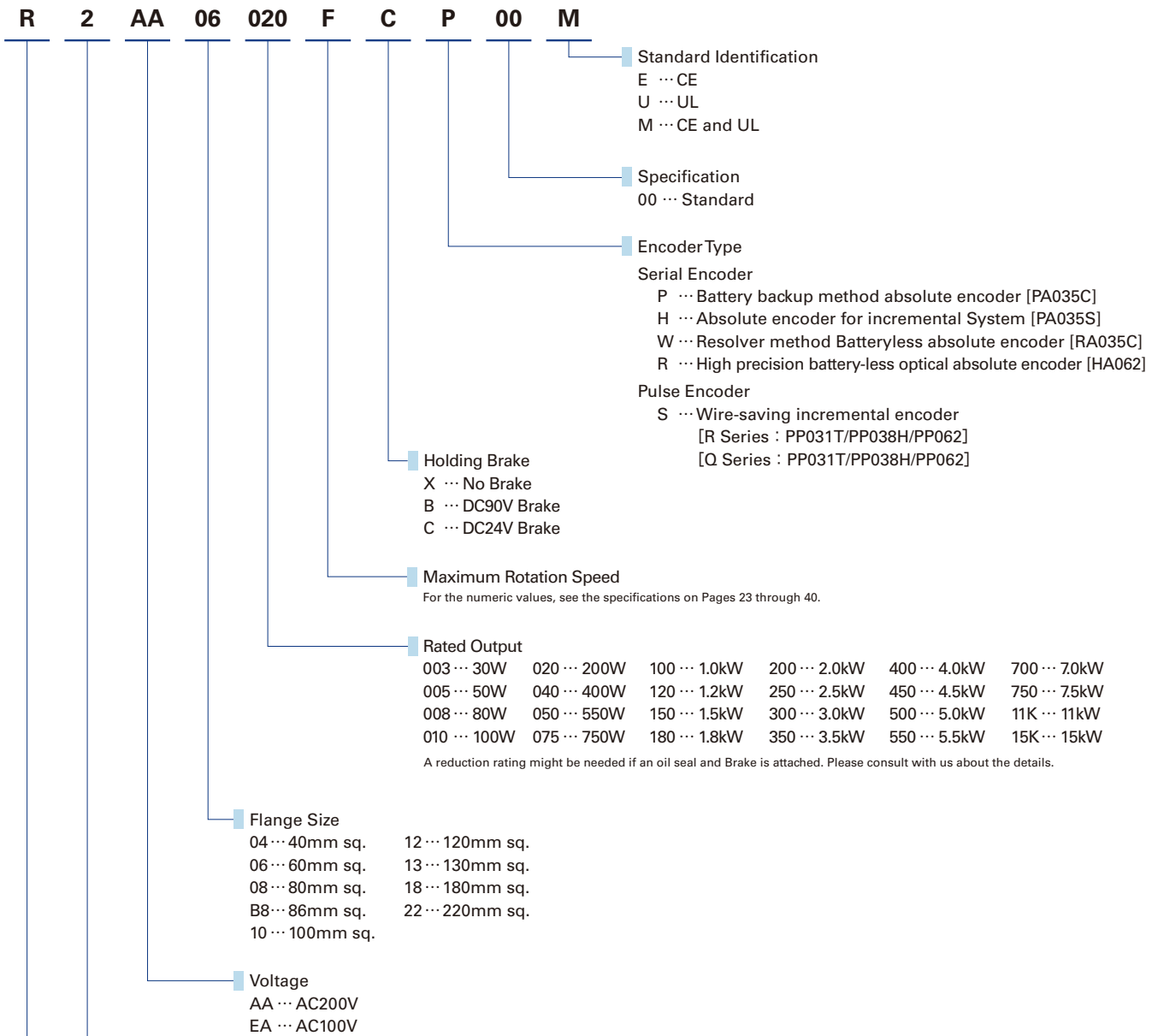

Encoder Specification

Serial encoder

Model	Partition number/rotation	Multiple Rotations	Encoder Type
PA035C	131072 (17bit) *	65536 (16bit)	Battery backup method absolute encoder
PA035S	131072 (17bit) *	—	Absolute encoder for Incremental system
RA035C	131072 (17bit)	65536 (16bit)	Resolver method batteryless absolute encoder
HA062	1048576 (20bit) 131072 (17bit)	65536 (16bit)	High precision battery-less optical absolute encoder Applicable motor size: 100mm sq. or more

*20 bit is available as an option.

Pulse encoder

Model	Partition number/rotation	Multiple Rotations	Encoder Type
PP031T PP038H PP062	8000 (2000P/R)	—	Wire-saving incremental encoder Maximum 40000 (Partition number/ rotation)

· For details on speed reducer installation, please contact us.

Servo Amplifier

Example: RS2 series servo amplifier models, input voltage AC200V, amplifier capacity 15A, with built-in regenerative resistance/with DB resistance, without safety function.

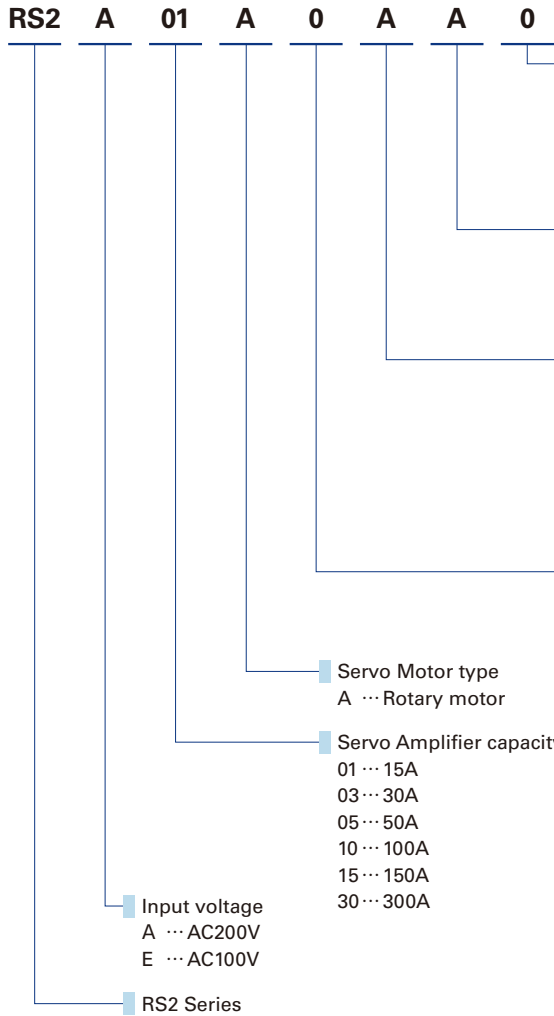

Option 2

	Safe Torque Off function
0	None
2	Available (without delay circuit)
4	Available (with delay circuit)

Option 1

A ... With built-in regenerative resistance/ with DB resistance
 L ... Without built-in regenerative resistance/ with DB resistance
 300A amplifier capacity is only available for the model without a built-in regenerative resistor.

Interface type

A...Analog pulse control, NPN (Sink) output
 B...Analog pulse control, PNP (Source) output
 K...EtherCAT interface

PNP

Generic output : PNP (Source) output :
 It takes external 24VDC as common power supply and outputs 24VDC when generic output is ON.

Motor Encoder Type

	EN1 (Motor encoder)	EN2 (External pulse encoder)
0	Serial encoder	—
2	Serial encoder	Pulse encoder
8	Pulse encoder	—
A	Pulse encoder	Pulse encoder

2 or A is selectable for a servo amplifier for a fully-closed system. Please specify 2 or A according to the motor encoder to be used.
 0 or 8 is only for a semi-closed system and is not selectable for a fully-closed system. Please note that a servo amplifier for a fully-closed system can be used for a semi-closed system.

Servo Motor type
 A ... Rotary motor

Servo Amplifier capacity
 01 ... 15A
 03 ... 30A
 05 ... 50A
 10 ... 100A
 15 ... 150A
 30 ... 300A

Input voltage
 A ... AC200V
 E ... AC100V

RS2 Series

- The motor parameters need to be set for the amplifier for use. Use the setup software.

Conformance to Safety Standards

Our standard servo amplifier has attained the UL, c-UL and EN Safety Standards. You can also employ servo motors that have attained the UL, c-UL and EN Standards.

* For the following models, acquisition preparations are underway.

UL and EN Standards acquisition preparations underway: R1 Servo Motor 180mm sq. (R1AA18 □□□□)



- Features and Functions
- Model No. List - Model Number Nomenclature
- System Configuration
- Standard Specifications
- Encoder Wiring Diagram
- External Wiring Diagram
- Dimensions
- Setup Software
- Option

Analog/Pulse Input Type Servo Amplifier 15A to 50A The photograph shows the 15A model.

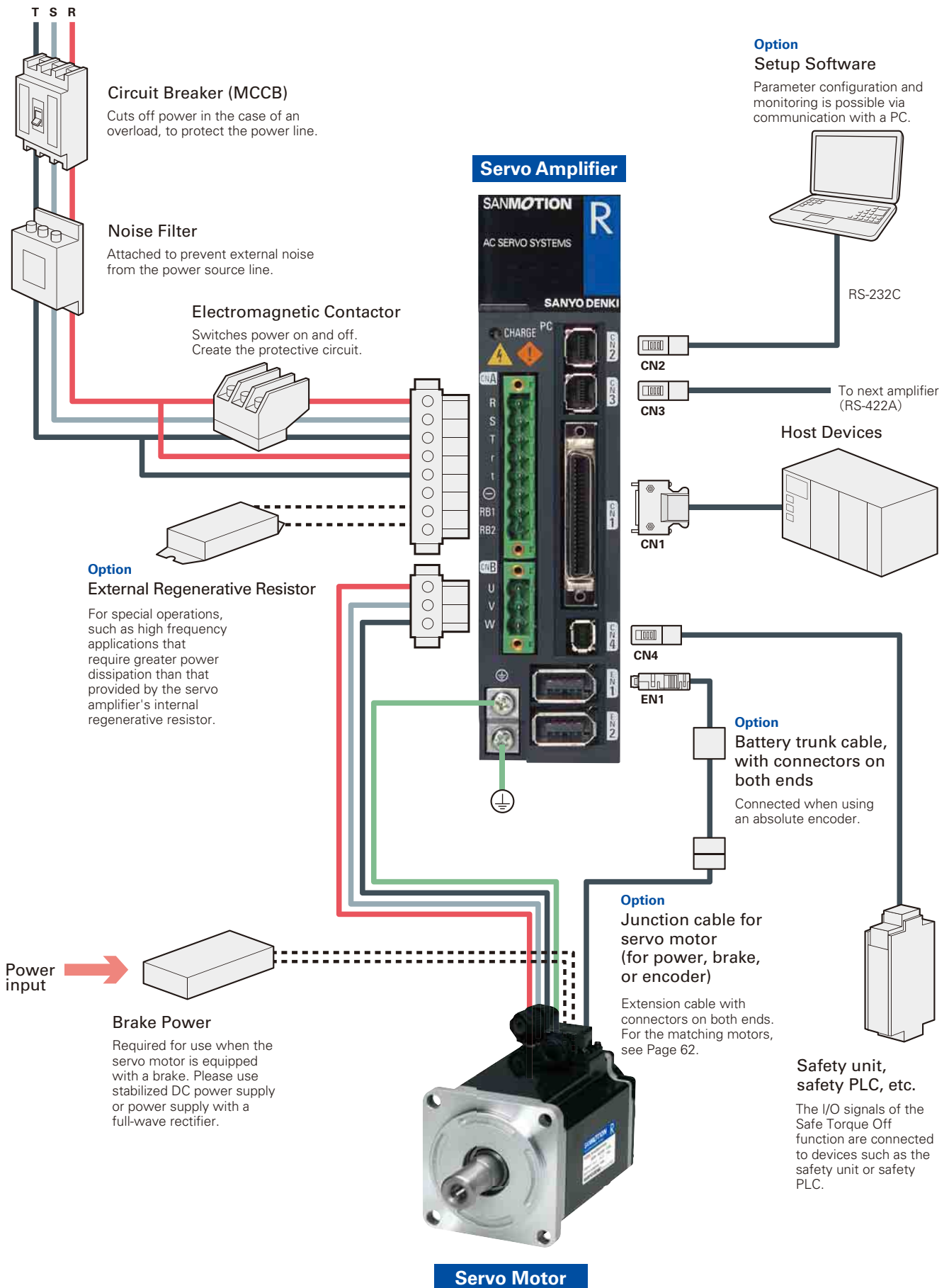

Analog/Pulse Input Type Servo Amplifier

100A to 300A

The photograph shows the 100A model.

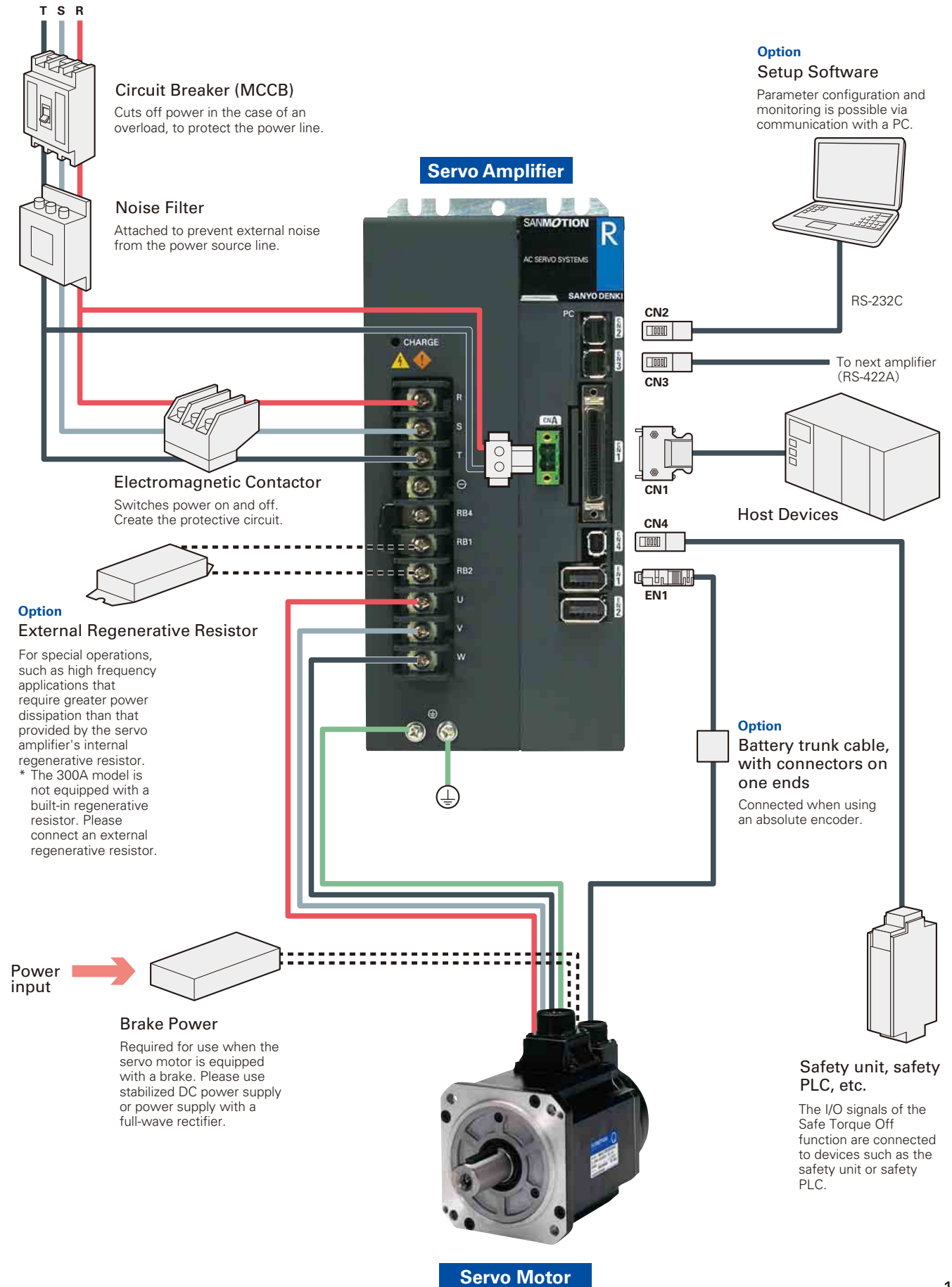

Features and Functions

Model No. List - Model Number Nomenclature

System Configuration

Standard Specifications

Encoder Wiring Diagram

External Wiring Diagram

Dimensions

Setup Software

Option

EtherCAT interface type servo amplifier 15A to 50A The photograph shows the 15A model.

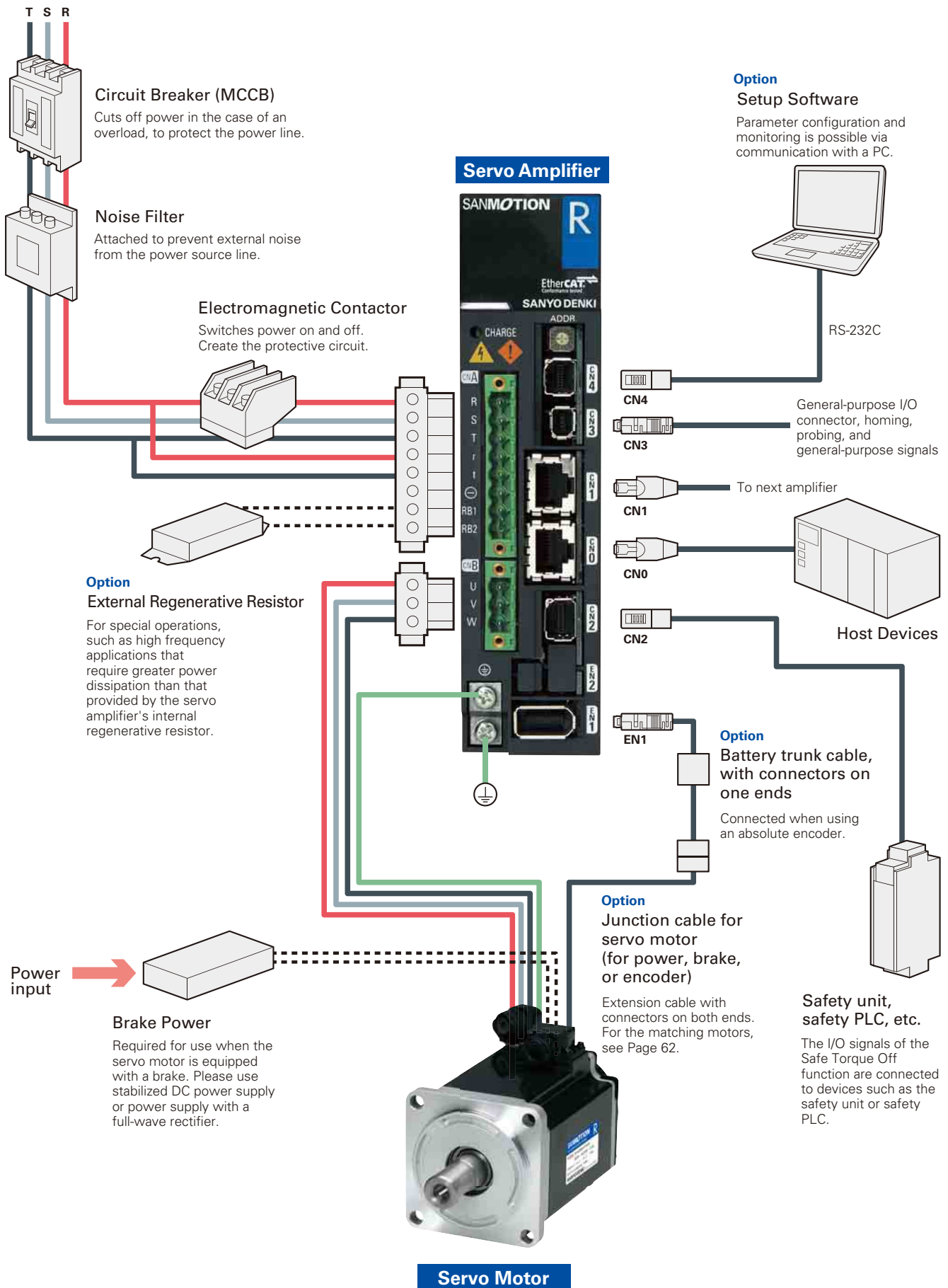

EtherCAT interface type servo amplifier

100A to 300A

The photograph shows the 100A model.

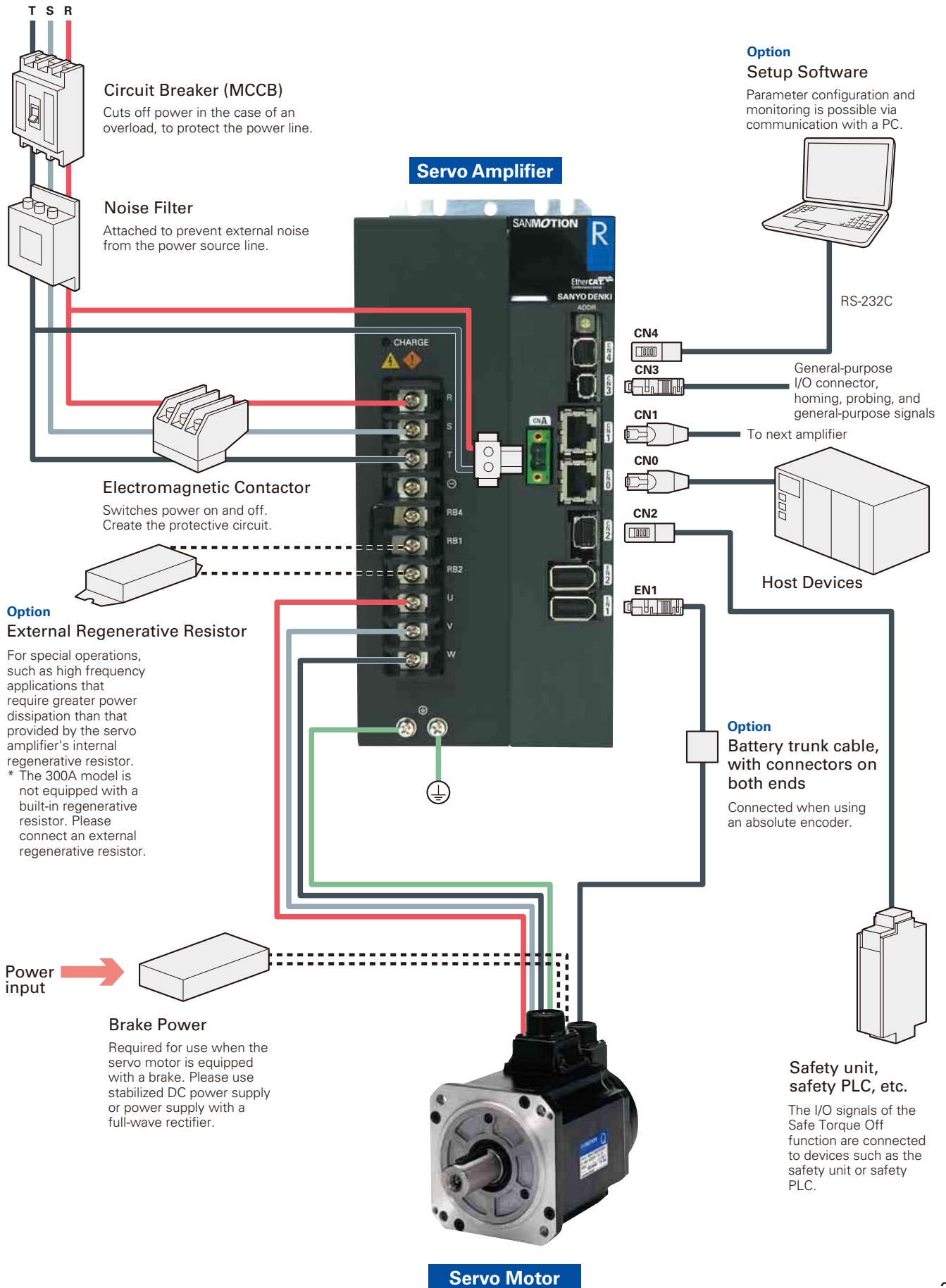

Features and Functions

Model No. List - Model Number Nomenclature

System Configuration

Standard Specifications

Encoder Wiring Diagram

External Wiring Diagram

Dimensions

Setup Software

Option

Servo Amplifier Specifications

Control function	Position control/Speed control/Torque control (Parameter changeover)	
Control system	IGBT : PWM control Sinusoidal drive	
Main Circuit Power ^{※1}	3-phase : AC200 to 230V+10, -15%, 50/60Hz±3Hz Single-phase : AC200 to 230V+10, -15%, 50/60Hz±3Hz ^{※2} Single-phase : AC100 to 115V+10, -15%, 50/60Hz±3Hz ^{※3}	
Control Power ^{※1}	Single-phase : AC200 to 230V+10, -15%, 50/60Hz±3Hz Single-phase : AC100 to 115V+10, -15%, 50/60Hz±3Hz ^{※3}	
Environment	Ambient temperature	0 to +55°C
	Storage temperature	-20 to +65°C
	Operation/Storage humidity	Below 90%RH (no condensation)
	Elevation	Below 1000m
	Vibration	4.9m/s ² Frequency range 10 to 55Hz tested for 2h in each direction X.Y.Z
	Shock	19.6m/s ²
Structure	Built-in tray type power supply	

※1

Power source voltage should be within the specified range AC200V

Power input type:

Specified power supply range = AC170V to AC253V

AC100V Power input type:
Specified power supply range = AC85V to AC127V

※2

The AC200V single-phase input types corresponds only to the RS2□01 (15A), RS2□03 (30A), and RS2□05 (50A).

※3

AC100V single-phase input type corresponds only to, RS2□01/RS2□03

Performance

Speed control range	1:5000 (Internal speed command)
Frequency characteristics	1200Hz (In case of high frequency sampling mode) *Varies depending on the model.

Built-in functions

Protection functions	Over current, Current detection error, Overload, Regeneration error, Amplifier overheating, External overheating, Over voltage, Main circuit power low voltage, Main circuit power supply open phase, Control power supply low voltage, Encoder error, Over speed, Speed control error, Speed feedback error, Excessive position, Position command pulse error, Built-in memory error, Parameter error	
LED display	Status display, Monitor display, Alarm display, Parameter setting, Adjustment mode	
Dynamic brake circuit	Built-in	
Regeneration process circuit	Built-in	
Monitor	Speed monitor (VMON)	2.0V±10% (at 1000min ⁻¹)
	Torque (Thrust) (TCMON)	2.0V±10% (at 100%)

Safety standard

Servo amplifier type	Safety standards		
All models	UL ratings	UL508C	
	EN standards	Low-voltage directive	· EN61800-5-1
		EMC directive	· EN55011 G1 ClassA · EN61000-6-2 · EN61800-3
Model with safety function	Function safety standards	· IEC61508, SIL2 · IEC62061, SILCL2	· ISO13849-1, Cat. 3, PL=d · EN954-1, Cat. 3

EtherCAT interface specifications

Physical layer	IEC61158-2 IEEE802.3u 100BASE-TX
Data link layer	IEC61158-3,-4 Type12
Application layer	IEC61158-5,-6 Type12
Device profile	IEC61800-7 Profile type1(CiA402) · CoE (CANopen over EtherCAT) · FoE (File access over EtherCAT)
Communication port	RJ45 connector (2 ports)
Baud rate	100 Mbps (Full duplex)
Max. No. of nodes	65535 nodes
Transmission distance/topology	Max. 100 m (between nodes)/Daisy-chain
Cable	Twisted-pair CAT5e (straight or cross)
Communication object	SDO (Service Data Object) PDO (Process Data Object)
PDO length	Output : Max.64Byte, Input : Max.64Byte Total: Max. 128 Bytes
Synchronization function	SYNC0, SYNC1 Event Synchronization Mode (DC Mode), Synchronous with SM2 Event Mode, Asynchronous Mode
Operation mode	Profile Position Mode, Profile Velocity Mode, Profile Torque Mode, Homing Mode, Cycle Sync Position Mode, Cycle Sync Velocity Mode, Cycle Sync Torque Mode
LED indicator	Port 0/1 link display, RUN display, error display
General Input/Output	2 inputs, 2 outputs (4 total)

PNP output (Analog/Pulse Input Type)

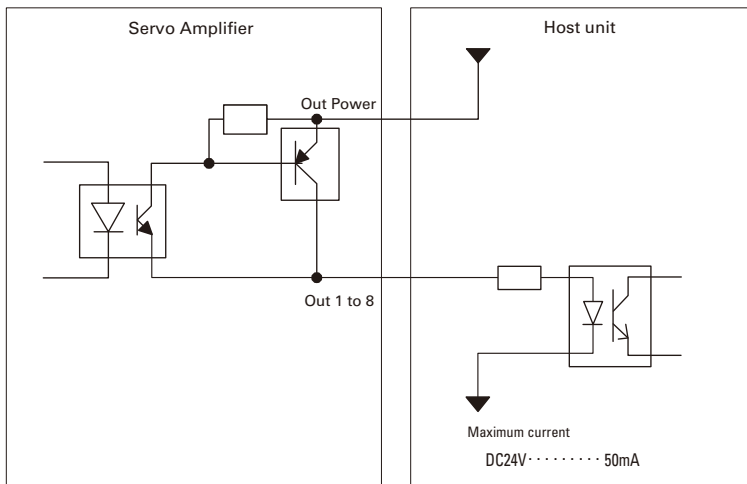

NPN output (Analog/Pulse Input Type)

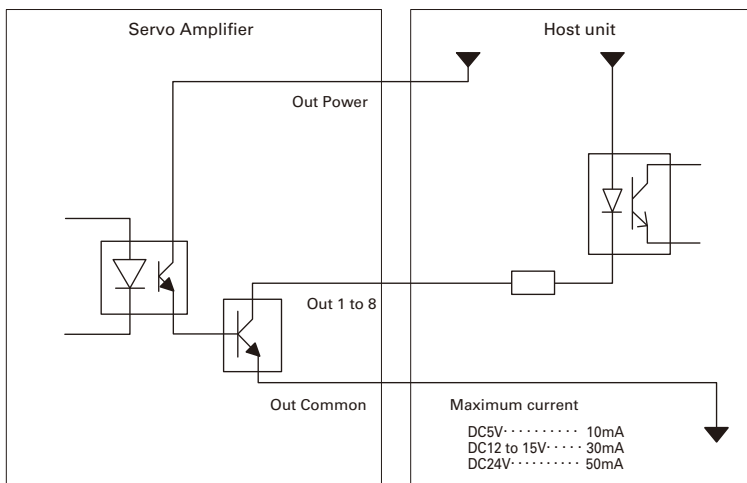
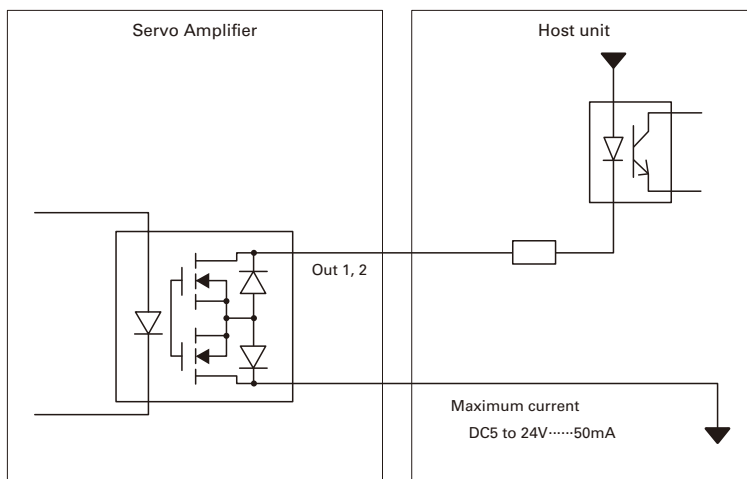

Photo relay output (EtherCAT interface type)



Specification



Servo Amplifier



R2

Servo Motor

High Efficiency and Low Ripple (Medium Inertia)

input voltage **AC100V**

Power supply range AC85V to AC127V

Servo Amplifier Model No.				RS2E01 <input type="checkbox"/> <input type="checkbox"/>		
Servo Motor Model No. and Flange Size				R2EA04003F 《40mm sq.》	R2EA04005F 《40mm sq.》	R2EA04008F 《40mm sq.》
	Status	Symbol	Unit			
Rated Output	★	P _R	kW	0.03	0.05	0.08
Rated Speed	★	N _R	min ⁻¹	3000	3000	3000
Maximum Speed	★	N _{max}	min ⁻¹	6000	6000	6000
Rated Torque	★	T _R	N·m	0.098	0.159	0.255
Continuous Stall Torque	★	T _S	N·m	0.108	0.167	0.255
Peak Stall Torque	★	T _P	N·m	0.37	0.59	0.86
Rated Armature Current	★	I _R	Arms	0.94	1.2	1.3
Armature Stall Current	★	I _S	Arms	1.0	1.3	1.3
Peak Armature Stall Current	★	I _P	Arms	3.7	4.9	4.5
Torque Constant	☆	K _T	N·m/Arms	0.116	0.142	0.22
Voltage Constant for each Phase	☆	K _{Eφ}	mV/min ⁻¹	4.04	4.97	7.7
Phase Resistance	☆	R _φ	Ω	4.0	3.0	2.9
Rated Power Rate	★	Q _R	kW/s	3.9	6.7	10
Electrical Time Constant	☆	t _e	ms	0.55	0.67	0.81
Mechanical Time Constant (Not including Encoder)	☆	t _m	ms	2.2	1.7	0.98
Roter Moment of Inertia ^{※ 1}		J _M	×10 ⁻⁴ kg·m ² (GD ² /4)	0.0247	0.0376	0.0627
Roter Moment of Inertia (Encoder)		J _S	×10 ⁻⁴ kg·m ² (GD ² /4)	0.0033 ^{※ 1}		
Servo Motor Mass ^{※ 1}		W _E	kg	0.35	0.39	0.51
Brake Static Friction Torque		T _B	N·m	0.32 MIN.		
Brake Rated Voltage		V _B	V	DC90V / DC24V ± 10%		
Brake Rated Current		I _B	A	0.07 / 0.27		
Roter Moment of Inertia (Brake)		J _B	×10 ⁻⁴ kg·m ² (GD ² /4)	0.0078		
Brake Mass		W	kg	0.27	0.27	0.27
Servo Motor Operating Temp, Rel.Humidity				Operating Temperature: 0 to 40°C, Relative Humidity: 90% maximum, no condensation		
Servo amplifier power supply capacity (rating)			kVA	0.2	0.2	0.3
CE and UL approved servo motors ^{※ 5}				Yes		
Servo motor protection code				IP67, IP65		
Size of aluminum plates for heat radiation during measurement				t6×250mm sq.		

※ 1 This is a instance with the battery-backup method absolute encoder [PA035C].

For the following encoders, please make inquiries:

- Batteryless absolute encoder
- Wire-saving Incremental encoder

For the servo amplifier weight, see page 51 and 52.

※ 2 Items with ★ and speed - torque characteristics indicate values after temperature rise saturation when used with a standard servo amplifier. The values are the typical values.

※ 3 ☆ :Indicates a typical value when the winding temperature is 20°C .

※ 4 A reduction rating might be needed if an oil seal and brake is attached. Please consult with us about the details.

※ 5 Our standard servo amplifiers are CE and UL approved.

Speed-Torque Characteristics

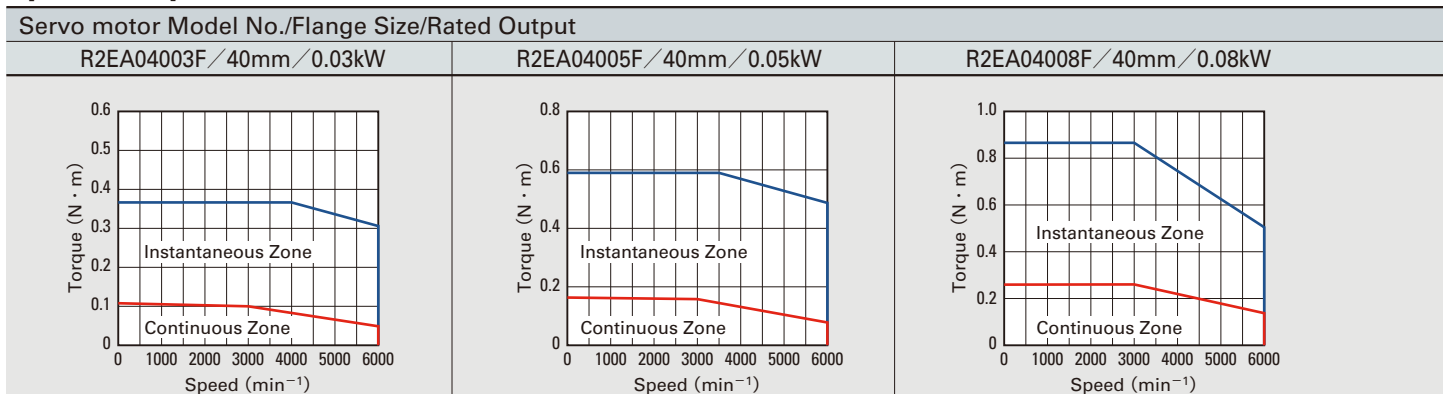

It is value when the input power supply is AC100V. The area decreases momentarily when the power supply voltage is less than 100V.

RS2E01□□	RS2E03□□	Servo Amplifier Model No.			
R2EA06010F 《60mm sq.》	R2EA06020F 《60mm sq.》	Servo Motor Model No. and Flange Size			
		Unit	Symbol	Status	
0.1	0.2	kW	P _R	★	Rated Output
3000	3000	min ⁻¹	N _R	★	Rated Speed
6000	6000	min ⁻¹	N _{max}	★	Maximum Speed
0.318	0.637	N·m	T _R	★	Rated Torque
0.318	0.686	N·m	T _S	★	Continuous Stall Torque
1.0	2.2	N·m	T _P	★	Peak Stall Torque
1.7	3.1	Arms	I _R	★	Rated Armature Current
1.7	3.2	Arms	I _S	★	Armature Stall Current
5.6	11.9	Arms	I _P	★	Peak Armature Stall Current
0.206	0.224	N·m/Arms	K _T	☆	Torque Constant
7.2	7.82	mV/min ⁻¹	K _{Eφ}	☆	Voltage Constant for each Phase
1.5	0.6	Ω	R _φ	☆	Phase Resistance
8.6	19	kW/s	Q _R	★	Rated Power Rate
1.9	2.6	ms	t _e	☆	Electrical Time Constant
1.2	0.79	ms	t _m	☆	Mechanical Time Constant (Not including Encoder)
0.117	0.219	×10 ⁻⁴ kg·m ² (GD ² /4)	J _M		Roter Moment of Inertia * 1
0.0033 * 1		×10 ⁻⁴ kg·m ² (GD ² /4)	J _S		Roter Moment of Inertia (Encoder)
0.71	0.96	kg	W _E		Servo Motor Mass * 1
0.36 MIN.	1.37 MIN.	N·m	T _B		Brake Static Friction Torque
DC90V / DC24V ± 10%		V	V _B		Brake Rated Voltage
0.07 / 0.27	0.11 / 0.32	A	I _B		Brake Rated Current
0.06		×10 ⁻⁴ kg·m ² (GD ² /4)	J _B		Roter Moment of Inertia (Brake)
0.34	0.39	kg	W		Brake Mass
Operating Temperature: 0 to 40°C, Relative Humidity: 90% maximum, no condensation					
0.4	0.6	kVA			Servo amplifier power supply capacity (rating)
Yes					
IP67, IP65					
t6×250mm sq.					
Size of aluminum plates for heat radiation during measurement					

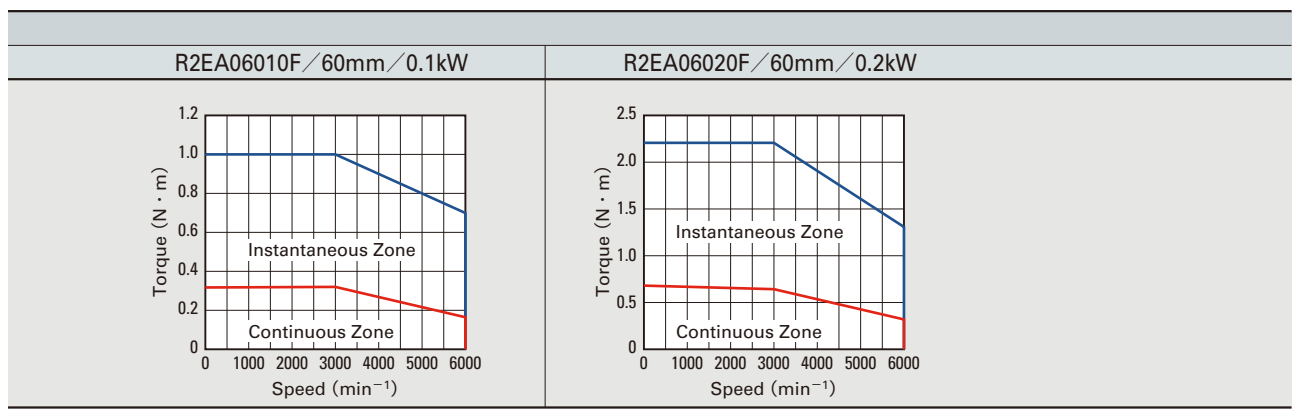

Specification



Servo Amplifier +



R2 Servo Motor High Efficiency and Low Ripple (Medium Inertia)

input voltage **AC200V**

Power supply range AC170V to AC253V

Servo Amplifier Model No.				RS2A01□□			
Servo Motor Model No. and Flange Size				R2AA04003F 《40mm sq.》	R2AA04005F 《40mm sq.》	R2AA04010F 《40mm sq.》	R2AA06010F 《60mm sq.》
	Status	Symbol	Unit				
Rated Output	★	P _R	kW	0.03	0.05	0.1	0.1
Rated Speed	★	N _R	min ⁻¹	3000	3000	3000	3000
Maximum Speed	★	N _{max}	min ⁻¹	6000	6000	6000	6000
Rated Torque	★	T _R	N·m	0.098	0.159	0.318	0.318
Continuous Stall Torque	★	T _S	N·m	0.108	0.167	0.318	0.353
Peak Stall Torque	★	T _P	N·m	0.37	0.59	1.18	1.13
Rated Armature Current	★	I _R	Arms	0.51	0.67	0.81	0.86
Armature Stall Current	★	I _S	Arms	0.56	0.69	0.81	0.86
Peak Armature Stall Current	★	I _P	Arms	2.15	2.8	3.3	3.5
Torque Constant	☆	K _T	N·m/Arms	0.201	0.246	0.424	0.375
Voltage Constant for each Phase	☆	K _{Eφ}	mV/min ⁻¹	7.0	8.6	14.8	13.1
Phase Resistance	☆	R _φ	Ω	12	9	9.3	4.8
Rated Power Rate	★	Q _R	kW/s	3.9	6.7	16	8.6
Electrical Time Constant	☆	t _e	ms	0.55	0.67	0.82	2
Mechanical Time Constant (Not including Encoder)	☆	t _m	ms	2.2	1.7	0.97	1.2
Roter Moment of Inertia * 1		J _M	×10 ⁻⁴ kg·m ² (GD ² /4)	0.0247	0.0376	0.0627	0.117
Roter Moment of Inertia (Encoder)		J _S	×10 ⁻⁴ kg·m ² (GD ² /4)	0.0033 * 1			
Servo Motor Mass * 1		W _E	kg	0.35	0.39	0.51	0.71
Brake Static Friction Torque		T _B	N·m	0.32 MIN.			0.36 MIN.
Brake Rated Voltage		V _B	V	DC90V / DC24V ± 10%			
Brake Rated Current		I _B	A	0.07 / 0.27			
Roter Moment of Inertia (Brake)		J _B	×10 ⁻⁴ kg·m ² (GD ² /4)	0.0078			0.06
Brake Mass		W	kg	0.27	0.27	0.27	0.34
Servo Motor Operating Temp, Rel.Humidity				Operating Temperature: 0 to 40°C, Relative Humidity: 90% maximum, no condensation			
Servo amplifier power supply capacity (rating)			kVA	0.2	0.2	0.4	0.4
CE and UL approved servo motors * 5				Yes			
Servo motor protection code				IP67, IP65			
Size of aluminum plates for heat radiation during measurement				t6 × 250mm sq.			

* 1 This is a instance with the battery-backup method absolute encoder [PA035C].
For the following encoders, please make inquiries:
· Batteryless absolute encoder
· Wire-saving Incremental encoder
For the servo amplifier weight, see page 51 and 52.

* 2 Items with ★ and speed - torque characteristics indicate values after temperature rise saturation when used with a standard servo amplifier. The values are the typical values.
* 3 ☆ :Indicates a typical value when the winding temperature is 20°C .
* 4 A reduction rating might be needed if an oil seal and brake is attached. Please consult with us about the details.
* 5 Our standard servo amplifiers are CE and UL approved.

Speed-Torque Characteristics

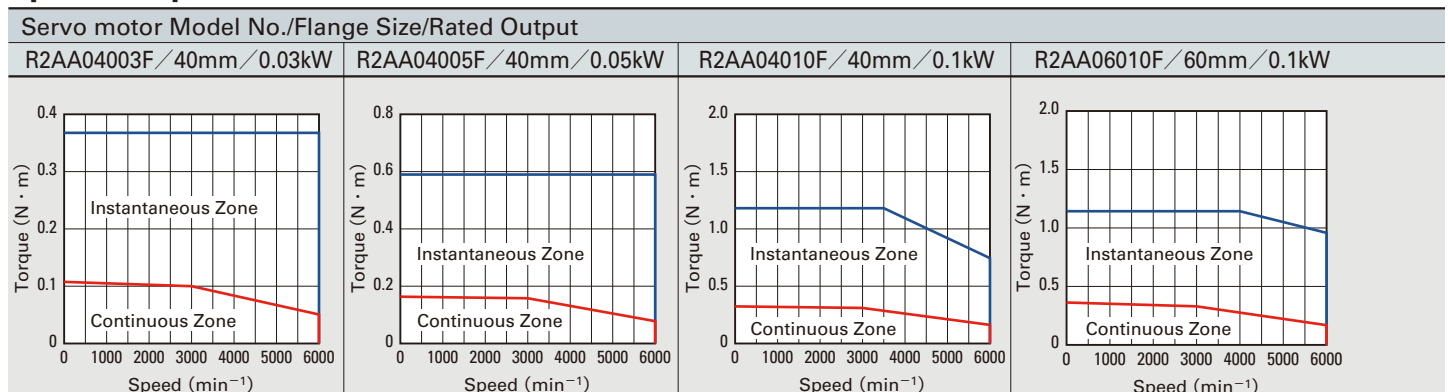

It is value when the input power supply is AC200V 3-phase circuit. The area decreases momentarily when the power supply voltage is less than 200V. Please contact us when the servo amplifier power supply is less than AC200V.

RS2A01□□				RS2A03□□	Servo Amplifier Model No.		
R2AA06020F 《60mm sq.》	R2AA06040H 《60mm sq.》	R2AA08020F 《80mm sq.》	R2AA06040F 《60mm sq.》	Servo Motor Model No. and Flange Size			
				Unit	Symbol	Status	
0.2	0.4	0.2	0.4	kW	PR	★	Rated Output
3000	3000	3000	3000	min ⁻¹	NR	★	Rated Speed
6000	3000	6000	6000	min ⁻¹	N _{max}	★	Maximum Speed
0.637	1.27	0.637	1.27	N·m	TR	★	Rated Torque
0.686	1.37	0.686	1.37	N·m	TS	★	Continuous Stall Torque
2.2	4.8	2.2	4.8	N·m	TP	★	Peak Stall Torque
1.5	1.7	1.5	2.8	Arms	IR	★	Rated Armature Current
1.6	1.8	1.5	2.8	Arms	IS	★	Armature Stall Current
5.6	7.1	4.8	10.8	Arms	IP	★	Peak Armature Stall Current
0.476	0.816	0.516	0.524	N·m/Arms	KT	☆	Torque Constant
16.6	28.5	18.0	18.3	mV/min ⁻¹	KEφ	☆	Voltage Constant for each Phase
2.7	3.3	2.3	1.36	Ω	Rφ	☆	Phase Resistance
19	39	8	39	kW/s	QR	★	Rated Power Rate
2.6	3.2	2.2	3.2	ms	te	☆	Electrical Time Constant
0.78	0.61	1.3	0.61	ms	tm	☆	Mechanical Time Constant (Not including Encoder)
0.219	0.412	0.52	0.412	X10 ⁻⁴ kg·m ² (GD ² /4)	JM		Roter Moment of Inertia * 1
0.0033 * 1				X10 ⁻⁴ kg·m ² (GD ² /4)	Js		Roter Moment of Inertia (Encoder)
0.96	1.4	1.3	1.4	kg	WE		Servo Motor Mass * 1
1.37 MIN.	1.37 MIN.	2.55 MIN.	1.37 MIN.	N·m	TB		Brake Static Friction Torque
DC90V / DC24V ± 10%				V	VB		Brake Rated Voltage
0.11 / 0.32	0.11 / 0.32	0.12 / 0.37	0.11 / 0.32	A	IB		Brake Rated Current
0.06	0.060	0.25	0.06	X10 ⁻⁴ kg·m ² (GD ² /4)	JB		Roter Moment of Inertia (Brake)
0.39	0.39	0.89	0.39	kg	W		Brake Mass
Operating Temperature: 0 to 40°C, Relative Humidity: 90% maximum, no condensation							Servo Motor Operating Temp, Rel. Humidity
0.8	1.0	0.8	1.0	kVA			Servo amplifier power supply capacity (rating)
Yes							CE and UL approved servo motors * 5
IP67, IP65							Servo motor protection code
t6 × 250mm sq.							Size of aluminum plates for heat radiation during measurement

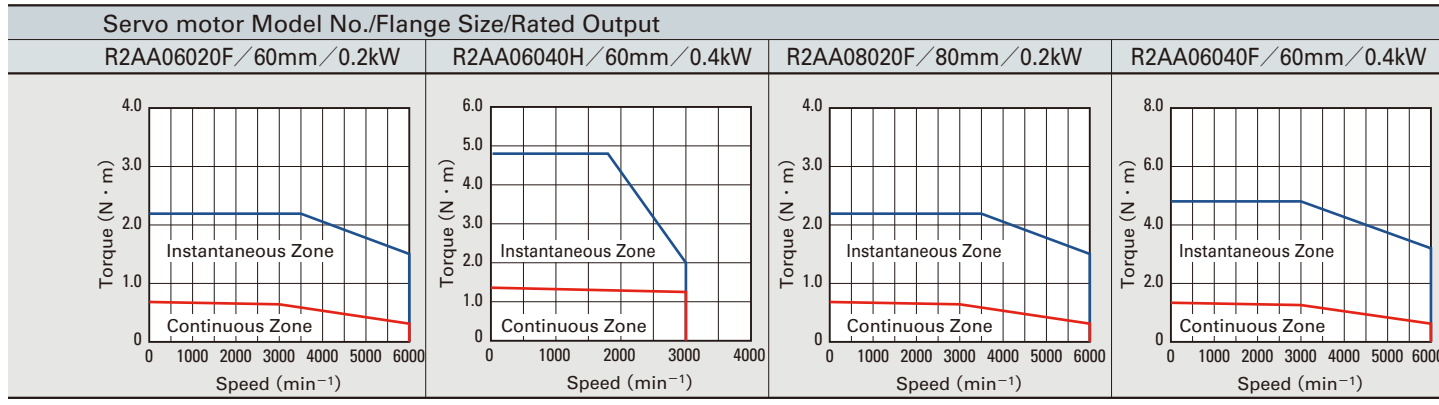

Specification



Servo Amplifier +



R2 Servo Motor High Efficiency and Low Ripple (Medium Inertia)

input voltage **AC200V**

Power supply range AC170V to AC253V

Servo Amplifier Model No.				RS2A03 <input type="checkbox"/> <input type="checkbox"/>			
Servo Motor Model No. and Flange Size				R2AA08040F 《80mm sq.》	R2AA08075F 《80mm sq.》	R2AAB8100H 《86mm sq.》	R2AA10075F 《100mm sq.》
	Status	Symbol	Unit				
Rated Output	★	P _R	kW	0.4	0.75	1.0	0.75
Rated Speed	★	N _R	min ⁻¹	3000	3000	3000	3000
Maximum Speed	★	N _{max}	min ⁻¹	6000	6000	3000	6000
Rated Torque	★	T _R	N·m	1.27	2.39	3.18	2.39
Continuous Stall Torque	★	T _S	N·m	1.37	2.55	3.92	2.55
Peak Stall Torque	★	T _P	N·m	4.4	8.5	11.6	8.6
Rated Armature Current	★	I _R	Arms	2.6	4.6	4.6	4.4
Armature Stall Current	★	I _S	Arms	2.6	4.6	4.7	4.6
Peak Armature Stall Current	★	I _P	Arms	8.9	15.5	15.5	15.5
Torque Constant	☆	K _T	N·m/Arms	0.559	0.559	0.825	0.582
Voltage Constant for each Phase	☆	K _{Eφ}	mV/min ⁻¹	19.5	19.5	28.8	20.3
Phase Resistance	☆	R _φ	Ω	0.93	0.4	0.85	0.69
Rated Power Rate	★	Q _R	kW/s	16	31	42	29
Electrical Time Constant	☆	t _e	ms	2.5	3	4.6	7.0
Mechanical Time Constant (Not including Encoder)	☆	t _m	ms	0.93	0.7	0.89	1.2
Roter Moment of Inertia * 1		J _M	×10 ⁻⁴ kg·m ² (GD ² /4)	1.04	1.82	2.38	2.00
Roter Moment of Inertia (Encoder)		J _S	×10 ⁻⁴ kg·m ² (GD ² /4)	0.0033 * 1			
Servo Motor Mass * 1		W _E	kg	1.7	2.7	3.6	3.3
Brake Static Friction Torque		T _B	N·m	2.55 MIN.		3.92 MIN.	
Brake Rated Voltage		V _B	V	DC90V / DC24V ± 10%			
Brake Rated Current		I _B	A	0.12 / 0.37		0.09 / 0.30	
Roter Moment of Inertia (Brake)		J _B	×10 ⁻⁴ kg·m ² (GD ² /4)	0.25		0.343	
Brake Mass		W	kg	0.89	0.89	0.84	0.9
Servo Motor Operating Temp, Rel.Humidity				Operating Temperature: 0 to 40°C, Relative Humidity: 90% maximum, no condensation			
Servo amplifier power supply capacity (rating)			kVA	1.0	1.7	2.0	1.7
CE and UL approved servo motors * 5				Yes			
Servo motor protection code				IP67, IP65			
Size of aluminum plates for heat radiation during measurement				t6 × 250mm sq.		t12 × 305mm sq.	

* 1 This is an instance with the battery-backup method absolute encoder [PA035C].

For the following encoders, please make inquiries:

· Batteryless absolute encoder

· Wire-saving Incremental encoder [PP031T]

For the servo amplifier weight, see page 51 and 52.

* 2 Items with ★ and speed - torque characteristics indicate values after temperature rise saturation when used with a standard servo amplifier. The values are the typical values.

* 3 ☆ :Indicates a typical value when the winding temperature is 20°C .

* 4 A reduction rating might be needed if an oil seal and brake is attached. Please consult with us about the details.

* 5 Our standard servo amplifiers are CE and UL approved.

Speed-Torque Characteristics

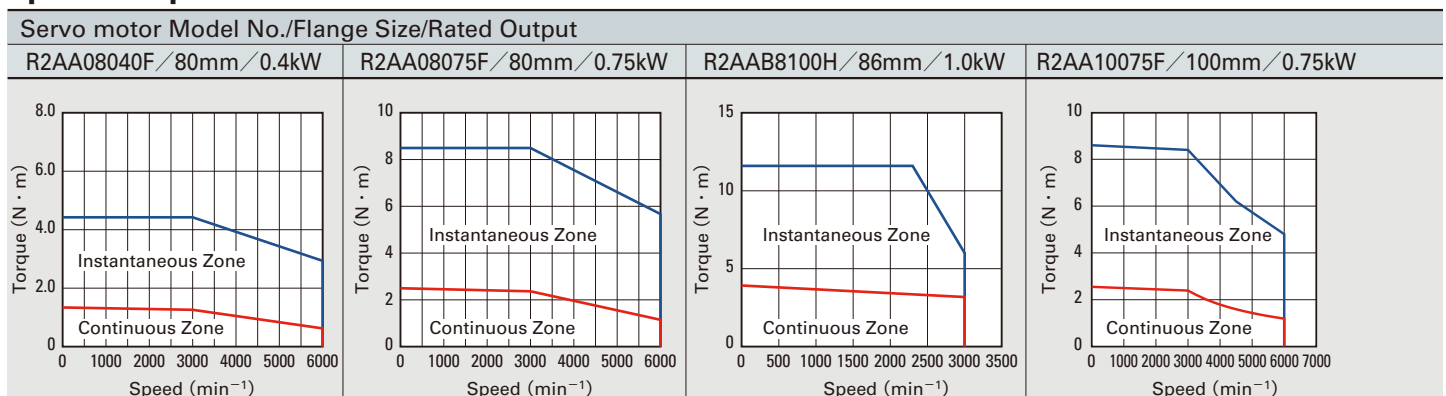

It is value when the input power supply is AC200V 3-phase circuit. The area decreases momentarily when the power supply voltage is less than 200V. Please contact us when the servo amplifier power supply is less than AC200V.

RS2A03 □□			RS2A05 □□		Servo Amplifier Model No.			
R2AA13050H 《130mm sq.》	R2AA13050D 《130mm sq.》	R2AA13120B 《130mm sq.》	R2AAB8075F 《86mm sq.》	R2AAB8100F 《86mm sq.》	Servo Motor Model No. and Flange Size			
					Unit	Symbol	Status	
0.55	0.55	1.2	0.75	1.0	kW	P _R	★	Rated Output
2000	2000	2000	3000	3000	min ⁻¹	N _R	★	Rated Speed
3500	5000	2000	6000	6000	min ⁻¹	N _{max}	★	Maximum Speed
2.6	2.6	5.7	2.38	3.18	N·m	T _R	★	Rated Torque
3.0	2.6	6.0	2.94	3.92	N·m	T _S	★	Continuous Stall Torque
9.0	7.0	16	11.0	14.3	N·m	T _P	★	Peak Stall Torque
4.2	5.2	5.2	4.7	6.0	Arms	I _R	★	Rated Armature Current
4.6	5.2	5.2	5.5	6.8	Arms	I _S	★	Armature Stall Current
15.5	15.5	15.5	23.7	25.7	Arms	I _P	★	Peak Armature Stall Current
0.67	0.53	1.09	0.547	0.582	N·m/Arms	K _T	☆	Torque Constant
23.5	18.5	37.8	19.1	20.3	mV/min ⁻¹	K _{Eφ}	☆	Voltage Constant for each Phase
0.65	0.39	0.64	0.62	0.44	Ω	R _φ	☆	Phase Resistance
22	22	54	35	42	kW/s	Q _R	★	Rated Power Rate
14	14	16	4.2	4.3	ms	te	☆	Electrical Time Constant
1.3	1.3	0.98	1.00	0.93	ms	tm	☆	Mechanical Time Constant (Not including Encoder)
3.1	3.1	6.0	1.64	2.38	×10 ⁻⁴ kg·m ² (GD ² /4)	J _M		Roter Moment of Inertia *1
0.0033 *1					×10 ⁻⁴ kg·m ² (GD ² /4)	J _S		Roter Moment of Inertia (Encoder)
4.5	4.5	6.1	2.9	3.6	kg	WE		Servo Motor Mass *1
3.5 MIN.	3.5 MIN.	9.0 MIN.	3.92 MIN.	3.92 MIN.	N·m	T _B		Brake Static Friction Torque
DC90V / DC24V ± 10%					V	VB		Brake Rated Voltage
0.15 / 0.41	0.15 / 0.41	0.17 / 0.51	0.09 / 0.30	0.09 / 0.30	A	IB		Brake Rated Current
0.5	0.5	0.5	0.34	0.34	×10 ⁻⁴ kg·m ² (GD ² /4)	J _B		Roter Moment of Inertia (Brake)
1.3	1.3	1.5	0.84	0.84	kg	W		Brake Mass
Operating Temperature: 0 to 40°C, Relative Humidity: 90% maximum, no condensation								Servo Motor Operating Temp, Rel. Humidity
1.5	1.5	2.7	1.6	2.5	kVA			Servo amplifier power supply capacity (rating)
Yes			Yes	Yes				CE and UL approved servo motors *5
IP65			IP67, IP65					Servo motor protection code
t20 × 305mm sq.	t20 × 400mm sq.	t12 × 305mm sq.						Size of aluminum plates for heat radiation during measurement

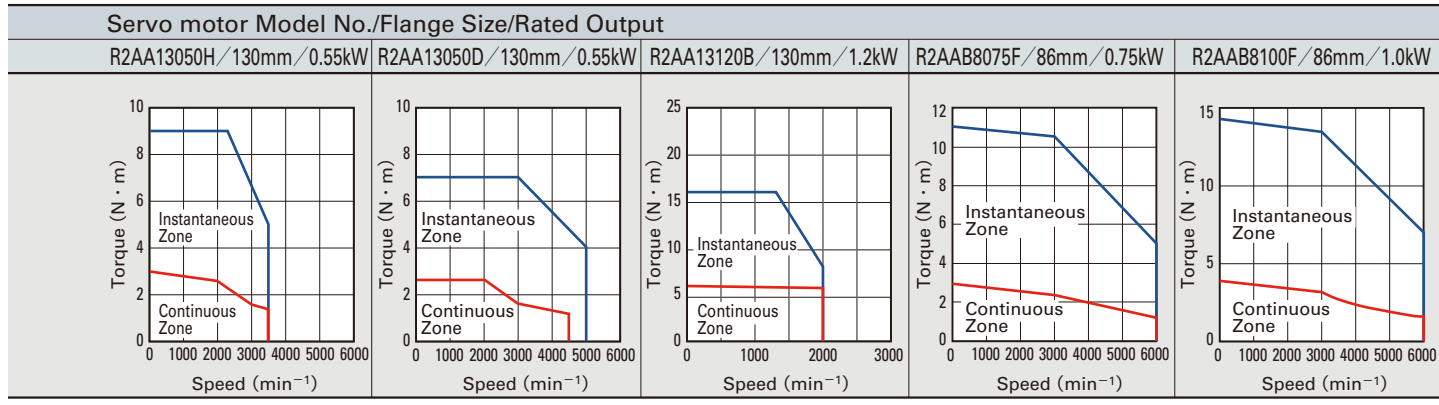

Specification



Servo Amplifier +



R2 Servo Motor High Efficiency and Low Ripple (Medium Inertia)

input voltage **AC200V**

Power supply range AC170V to AC253V

Servo Amplifier Model No.				RS2A05□□			
Servo Motor Model No. and Flange Size				R2AA10100F 《100mm sq.》	R2AA13120L 《130mm sq.》	R2AA13120D 《130mm sq.》	R2AA13180H 《130mm sq.》
	Status	Symbol	Unit				
Rated Output	★	PR	kW	1.0	1.2	1.2	1.8
Rated Speed	★	NR	min ⁻¹	3000	2000	2000	2000
Maximum Speed	★	N _{max}	min ⁻¹	6000	3000	5000	3500
Rated Torque	★	TR	N·m	3.18	5.7	5.7	8.6
Continuous Stall Torque	★	TS	N·m	3.92	6.0	6.0	10.0
Peak Stall Torque	★	TP	N·m	14.3	20	16	22
Rated Armature Current	★	IR	Arms	5.7	7.6	9.1	11.0
Armature Stall Current	★	IS	Arms	6.8	8.4	9.3	11.8
Peak Armature Stall Current	★	IP	Arms	25.7	26.5	25.4	26.5
Torque Constant	☆	KT	N·m/Arms	0.584	0.77	0.65	0.89
Voltage Constant for each Phase	☆	KEφ	mV/min ⁻¹	20.4	27.0	22.7	31.1
Phase Resistance	☆	Rφ	Ω	0.35	0.35	0.23	0.23
Rated Power Rate	★	QR	kW/s	29	54	54	82
Electrical Time Constant	☆	te	ms	8.3	15	16	18
Mechanical Time Constant (Not including Encoder)	☆	tm	ms	1.1	1.1	0.98	0.78
Roter Moment of Inertia * 1		JM	×10 ⁻⁴ kg·m ² (GD ² /4)	3.50	6.0	6.0	9.0
Roter Moment of Inertia (Encoder)		Js	×10 ⁻⁴ kg·m ² (GD ² /4)	0.0033 * 1			
Servo Motor Mass * 1		WE	kg	4.1	6.1	6.1	7.7
Brake Static Friction Torque		TB	N·m	3.92 MIN.	9.0 MIN.	9.0 MIN.	9.0 MIN.
Brake Rated Voltage		VB	V	DC90V / DC24V ± 10%			
Brake Rated Current		IB	A	0.09 / 0.30	0.17 / 0.51	0.17 / 0.51	0.17 / 0.51
Roter Moment of Inertia (Brake)		JB	×10 ⁻⁴ kg·m ² (GD ² /4)	0.343	0.5	0.5	0.5
Brake Mass		W	kg	0.9	1.5	1.5	1.5
Servo Motor Operating Temp, Rel.Humidity				Operating Temperature: 0 to 40°C, Relative Humidity: 90% maximum, no condensation			
Servo amplifier power supply capacity (rating)			kVA	2.3	2.7	2.7	3.6
CE and UL approved servo motors * 4				Yes			
Servo motor protection code				IP67, IP65		IP65	
Size of aluminum plates for heat radiation during measurement				t12×305mm sq.	t20×400mm sq.	t20×470mm sq.	

* 1 This is an instance with the battery-backup method absolute encoder [PA035C].

For the following encoders, please make inquiries:

· Batteryless absolute encoder

· Wire-saving Incremental encoder [PP031T]

For the servo amplifier weight, see page 51 and 52.

* 2 Items with ★ and speed - torque characteristics indicate values after temperature rise saturation when used with a standard servo amplifier. The values are the typical values.

* 3 ☆ :Indicates a typical value when the winding temperature is 20°C .

* 4 Our standard servo amplifiers are CE and UL approved.

Speed-Torque Characteristics

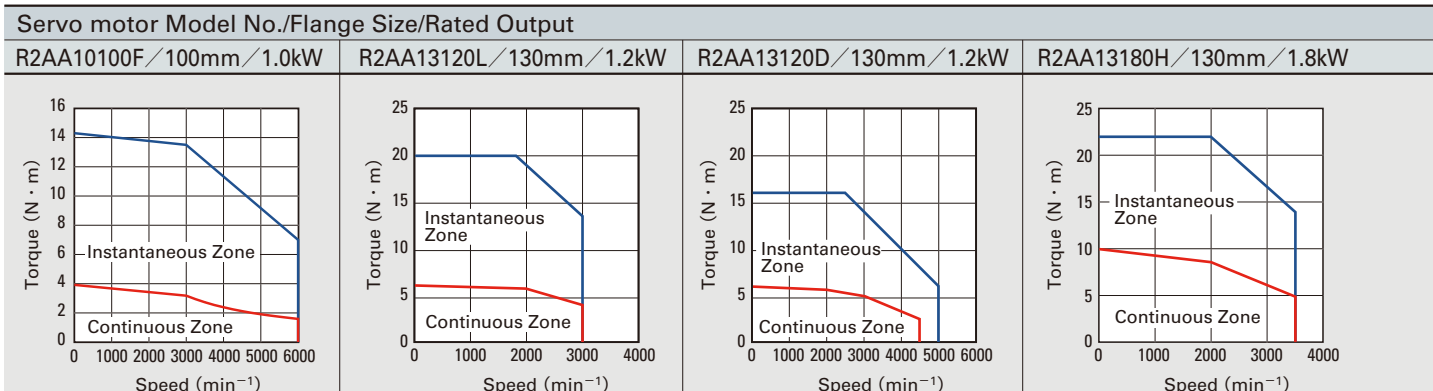

It is value when the input power supply is AC200V 3-phase circuit. The area decreases momentarily when the power supply voltage is less than 200V. Please contact us when the servo amplifier power supply is less than AC200V.

RS2A05□□		RS2A10□□		Servo Amplifier Model No.			
R2AA13200L 《130mm sq.》	R2AA13180D 《130mm sq.》	R2AA13200D 《130mm sq.》	R2AA18350L 《180mm sq.》	Servo Motor Model No. and Flange Size			
				Unit	Symbol	Status	
2	1.8	2	3.5	kW	PR	★	Rated Output
2000	2000	2000	2000	min ⁻¹	NR	★	Rated Speed
3000	5000	5000	3000	min ⁻¹	N _{max}	★	Maximum Speed
9.5	8.6	9.5	17	N·m	TR	★	Rated Torque
12	10.0	12	22.0	N·m	TS	★	Continuous Stall Torque
24	25	30	49	N·m	TP	★	Peak Stall Torque
11.0	15.6	14.3	19.1	Arms	IR	★	Rated Armature Current
12.0	17.3	17.5	23.7	Arms	IS	★	Armature Stall Current
26.5	43.0	45.5	55.0	Arms	IP	★	Peak Armature Stall Current
0.97	0.63	0.70	1.00	N·m/Arms	KT	☆	Torque Constant
33.7	21.8	24.3	34.8	mV/min ⁻¹	KEφ	☆	Voltage Constant for each Phase
0.22	0.13	0.11	0.085	Ω	Rφ	☆	Phase Resistance
74	82	74	72	kW/s	QR	★	Rated Power Rate
17	16	18	18	ms	te	☆	Electrical Time Constant
0.86	0.89	0.83	1.0	ms	tm	☆	Mechanical Time Constant (Not including Encoder)
12.2	9.0	12.2	40	X10 ⁻⁴ kg·m ² (GD ² /4)	JM		Roter Moment of Inertia * 1
0.0033 * 1				X10 ⁻⁴ kg·m ² (GD ² /4)	Js		Roter Moment of Inertia (Encoder)
10	7.7	10	15.5	kg	WE		Servo Motor Mass * 1
12 MIN.	9.0 MIN.	12 MIN.	22 MIN.	N·m	TB		Brake Static Friction Torque
DC90V / DC24V ± 10%				V	VB		Brake Rated Voltage
0.17 / 0.66	0.17 / 0.51	0.17 / 0.66	0.32 / 1.2	A	IB		Brake Rated Current
0.5	0.5	0.5	5.1	X10 ⁻⁴ kg·m ² (GD ² /4)	JB		Roter Moment of Inertia (Brake)
1.5	1.5	1.5	2.4	kg	W		Brake Mass
Operating Temperature: 0 to 40°C, Relative Humidity: 90% maximum, no condensation							Servo Motor Operating Temp, Rel. Humidity
5.0	4.0	5.0	6.0	kVA			Servo amplifier power supply capacity (rating)
Yes	Yes	Yes					CE and UL approved servo motors * 5
IP65							Servo motor protection code
t20×470mm sq.							Size of aluminum plates for heat radiation during measurement

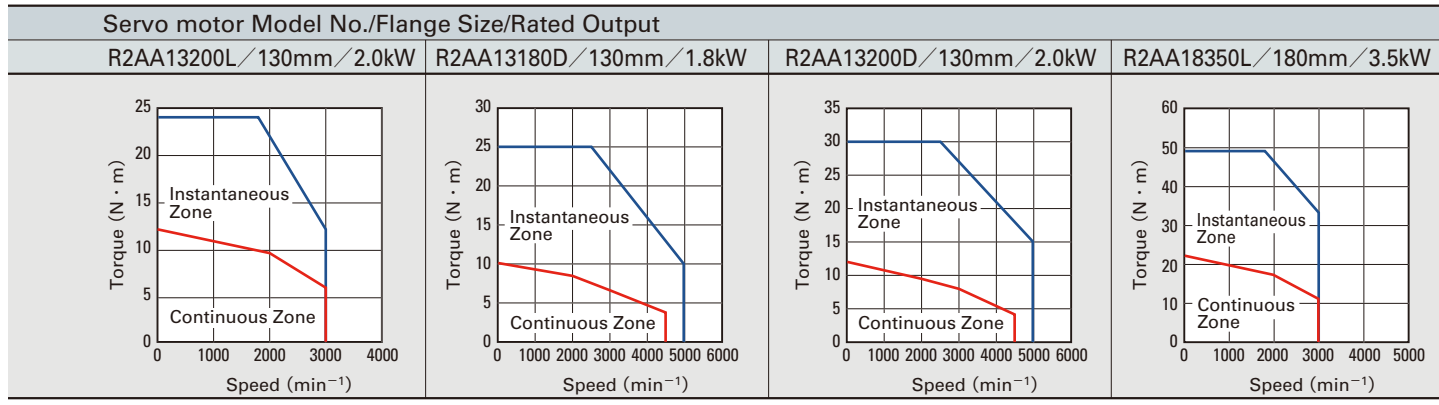

Specification



Servo Amplifier + R2 Servo Motor High Efficiency and Low Ripple (Medium Inertia)



input voltage **AC200V**

Power supply range AC170V to AC253V

Servo Amplifier Model No.				RS2A10□□	RS2A15□□		
Servo Motor Model No. and Flange Size				R2AA22350L 《220mm sq.》	R2AA18350D 《180mm sq.》	R2AA18450H 《180mm sq.》	R2AA18550R 《180mm sq.》
	Status	Symbol	Unit				
Rated Output	★	PR	kW	3.5	3.5	4.5	5.5
Rated Speed	★	NR	min ⁻¹	2000	2000	2000	1500
Maximum Speed	★	N _{max}	min ⁻¹	4000	4000	3500	2500
Rated Torque	★	T _R	N·m	17	17	21.5	35
Continuous Stall Torque	★	T _S	N·m	22	22.0	30.0	37.3
Peak Stall Torque	★	T _P	N·m	50	60	75	90
Rated Armature Current	★	I _R	Arms	18.0	21.7	23.7	31.6
Armature Stall Current	★	I _S	Arms	22.0	27.0	31.7	32.9
Peak Armature Stall Current	★	I _P	Arms	55.0	83.0	83.0	83.0
Torque Constant	☆	K _T	N·m/Arms	1.04	0.88	1.02	1.23
Voltage Constant for each Phase	☆	K _{Eφ}	mV/min ⁻¹	36.2	30.6	35.6	42.8
Phase Resistance	☆	R _φ	Ω	0.094	0.075	0.065	0.059
Rated Power Rate	★	Q _R	kW/s	69	72	92	180
Electrical Time Constant	☆	te	ms	34	16	18	22
Mechanical Time Constant (Not including Encoder)	☆	tm	ms	1.1	1.2	0.94	0.80
Roter Moment of Inertia *1		J _M	×10 ⁻⁴ kg·m ² (GD ² /4)	42	40	50	68
Roter Moment of Inertia (Encoder)		J _S	×10 ⁻⁴ kg·m ² (GD ² /4)	0.0033 *1			
Servo Motor Mass *1		WE	kg	18	15.5	19.5	27.7
Brake Static Friction Torque		T _B	N·m	32 MIN.	22 MIN.	32 MIN.	42 MIN.
Brake Rated Voltage		VB	V	DC90V / DC24V ± 10%			
Brake Rated Current		IB	A	0.32 / 1.2	0.32 / 1.2	0.27 / 1.0	0.27 / 1.0
Roter Moment of Inertia (Brake)		J _B	×10 ⁻⁴ kg·m ² (GD ² /4)	5.1	5.1	5.1	5.1
Brake Mass		W	kg	4.5	2.4	2.8	2.8
Servo Motor Operating Temp, Rel. Humidity				Operating Temperature: 0 to 40°C, Relative Humidity: 90% maximum, no condensation			
Servo amplifier power supply capacity (rating)			kVA	6.0	7.0	7.4	8.4
Cooling fan		P _F	W	—			
CE and UL approved servo motors *4				Yes			
Servo motor protection code				IP65			
Size of aluminum plates for heat radiation during measurement				t20 × 470mm sq.			t20 × 540mm sq.

*1 This is an instance with the battery-backup method absolute encoder [PA035C].
For the following encoders, please make inquiries:
· Batteryless absolute encoder
· Wire-saving Incremental encoder [PP031T]
For the servo amplifier weight, see page 51 and 52.

*2 Items with ★ and speed - torque characteristics indicate values after temperature rise saturation when used with a standard servo amplifier. The values are the typical values.
*3 ☆ :Indicates a typical value when the winding temperature is 20°C .
*4 Our standard servo amplifiers are CE and UL approved.

Speed-Torque Characteristics

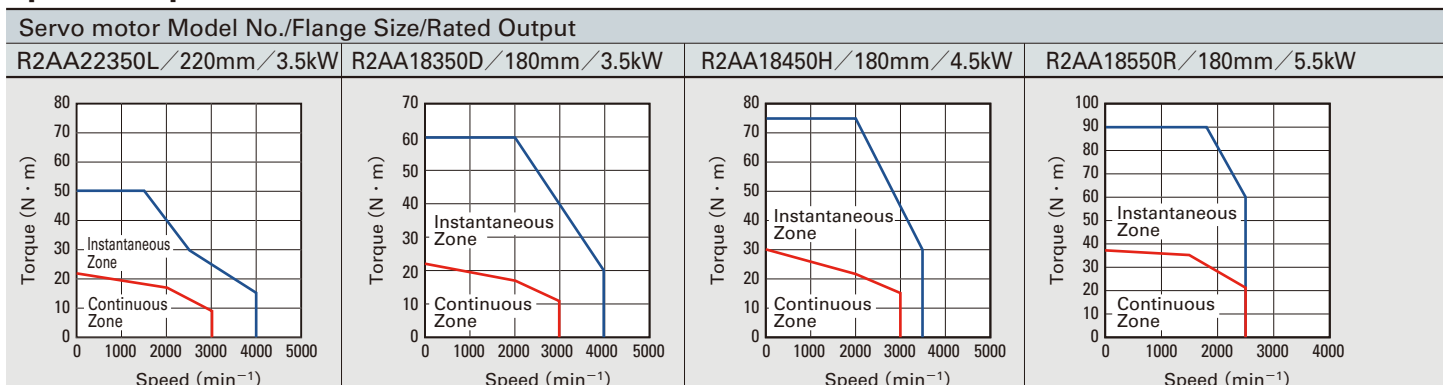

It is value when the input power supply is AC200V 3-phase circuit. The area decreases momentarily when the power supply voltage is less than 200V. Please contact us when the servo amplifier power supply is less than AC200V.

RS2A15□□		RS2A30□□		Servo Amplifier Model No.			
R2AA22500L 《220mm sq.》	R2AA18550H 《180mm sq.》	R2AA18750H 《180mm sq.》	R2AA1811KR 《180mm sq.》	Servo Motor Model No. and Flange Size			
				Unit	Symbol	Status	
5	5.5	7.5	11	kW	P _R	★	Rated Output
2000	1500	1500	1500	min ⁻¹	N _R	★	Rated Speed
4000	3000	3000	2500	min ⁻¹	N _{max}	★	Maximum Speed
24	35	48	70	N·m	T _R	★	Rated Torque
32	37.5	54.9	80.0	N·m	T _S	★	Continuous Stall Torque
75	107	140	170	N·m	T _P	★	Peak Stall Torque
22.0	46.2	51.2	61.9	Arms	I _R	★	Rated Armature Current
34.0	48.0	56.8	66.0	Arms	I _S	★	Armature Stall Current
83.0	155.0	155.0	155.0	Arms	I _P	★	Peak Armature Stall Current
1.00	0.84	1.04	1.25	N·m/Arms	K _T	☆	Torque Constant
34.9	29.3	36.6	43.8	mV/min ⁻¹	K _{Eφ}	☆	Voltage Constant for each Phase
0.047	0.030	0.030	0.035	Ω	R _φ	☆	Phase Resistance
105	180	235	445	kW/s	Q _R	★	Rated Power Rate
40	20	20	22	ms	te	☆	Electrical Time Constant
0.78	0.87	0.81	0.74	ms	tm	☆	Mechanical Time Constant (Not including Encoder)
55	68	98	110	×10 ⁻⁴ kg·m ² (GD ² /4)	J _M		Roter Moment of Inertia * 1
0.0033 * 1				×10 ⁻⁴ kg·m ² (GD ² /4)	J _S		Roter Moment of Inertia (Encoder)
22.5	27.7	35.7	40	kg	WE		Servo Motor Mass * 1
42 MIN.	42 MIN.	54.9 MIN.	100 MIN.	N·m	T _B		Brake Static Friction Torque
DC90V / DC24V ± 10%				V	VB		Brake Rated Voltage
0.32 / 1.2	0.27 / 1.0	0.37 / 1.4	0.5 / 1.9	A	IB		Brake Rated Current
5.1	5.1	4.5	9.7	×10 ⁻⁴ kg·m ² (GD ² /4)	JB		Roter Moment of Inertia (Brake)
5.5	2.8	4.5	8.9	kg	W		Brake Mass
Operating Temperature: 0 to 40°C, Relative Humidity: 90% maximum, no condensation							Servo Motor Operating Temp, Rel. Humidity
9.6	9.3	11.6	16.0	kVA			Servo amplifier power supply capacity (rating)
—			39/33 AC200V±10% Single-phase 50/60Hz	W	P _F		Cooling fan
Yes							CE and UL approved servo motors * 5
IP65 (Excluding cooling fan)							Servo motor protection code
t20 × 540mm sq.			t30 × 610mm sq.				Size of aluminum plates for heat radiation during measurement

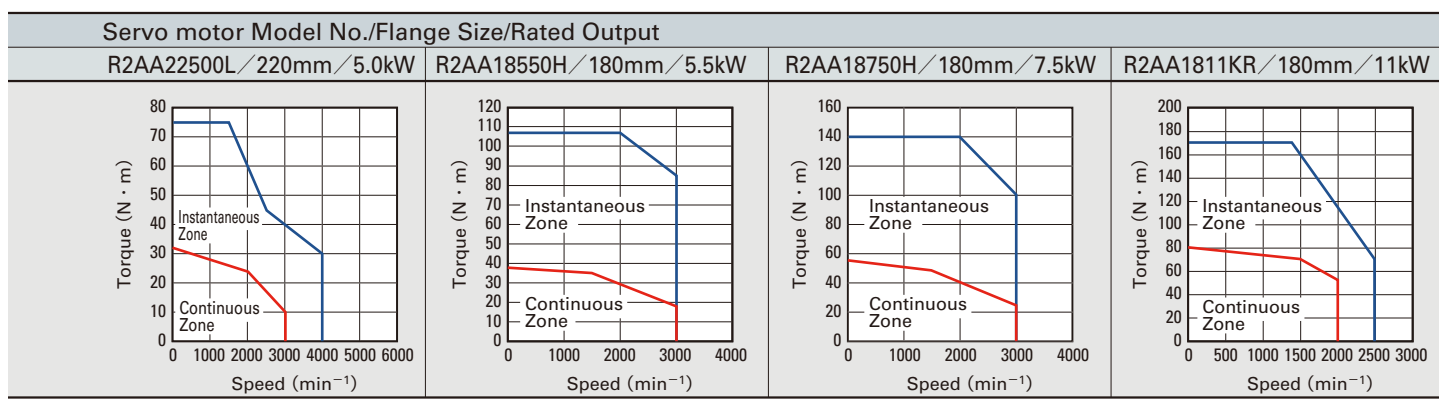

Specification



Servo Amplifier +



Q2 Servo Motor High Efficiency and Low Ripple (Medium Inertia)

input voltage **AC200V**

Power supply range AC170V to AC253V

Servo Amplifier Model No.				RS2A10A□	RS2A15A□	
Servo Motor Model No. and Flange Size				Q2AA18200H 《180mm sq.》	Q2AA22550B 《220mm sq.》	Q2AA22700S 《220mm sq.》
	Status	Symbol	Unit			
Rated Output	★	P _R	kW	2	5.5	7
Rated Speed	★	N _R	min ⁻¹	2000	1500	1000
Maximum Speed	★	N _{max}	min ⁻¹	3500	2000	1000
Rated Torque	★	T _R	N·m	9.5	35	67
Continuous Stall Torque	★	T _S	N·m	12	42	70
Peak Stall Torque	★	T _P	N·m	31.0	90	150
Rated Armature Current	★	I _R	Arms	15	30	34
Armature Stall Current	★	I _S	Arms	18	35.1	34
Peak Armature Stall Current	★	I _P	Arms	55	79.7	83
Torque Constant	☆	K _T	N·m/Arms	0.75	1.32	2.13
Voltage Constant for each Phase	☆	K _{Eφ}	mV/min ⁻¹	25.9	46	74.5
Phase Resistance	☆	R _φ	Ω	0.075	0.0464	0.057
Rated Power Rate	★	Q _R	kW/s	45.7	128.5	243
Electrical Time Constant	☆	t _e	ms	14.7	24	30
Mechanical Time Constant (Not including Encoder)	☆	t _m	ms	0.82	0.76	0.7
Rotor Moment of Inertia ^{※1}		J _M	×10 ⁻⁴ kg·m ² (GD ² /4)	20	95.3	185
Servo Motor Mass ^{※1}		W _E	kg	13.6	34.8	46
Brake Static Friction Torque		T _B	N·m	32	90	90
Brake Rated Voltage		V _B	V	DC90V / DC24V ± 10%		
Brake Rated Current		I _B	A	0.37 / 1.4	0.36 / 1.3	0.44 / 1.7
Rotor Moment of Inertia (Brake)		J _B	×10 ⁻⁴ kg·m ² (GD ² /4)	5.5	9.9	24
Brake Mass		W	kg	5	5.9	10.4
Servo Motor Operating Temp, Rel.Humidity				Operating Temperature: 0 to 40°C, Relative Humidity: 90% maximum, no condensation		
Servo amplifier power supply capacity (rating)			kVA	5.0	10.1	12.2
CE and UL approved servo motors ^{※4}				Yes		
Servo motor protection code				IP67		
Size of aluminum plates for heat radiation during measurement				t20 × 470mm sq.	t20 × 540mm sq.	

※1 Including wire-saving incremental encoder.

For the servo amplifier weight, see page 51 and 52.

※2 Items with ★ and speed - torque characteristics indicate values after temperature rise saturation when used with a standard servo amplifier. The values are the typical values.

※3 ☆:Indicates a typical value when the winding temperature is 20°C.

※4 Our standard servo amplifiers are CE and UL approved.

Speed-Torque Characteristics

Servo motor Model No./Flange Size/Rated Output

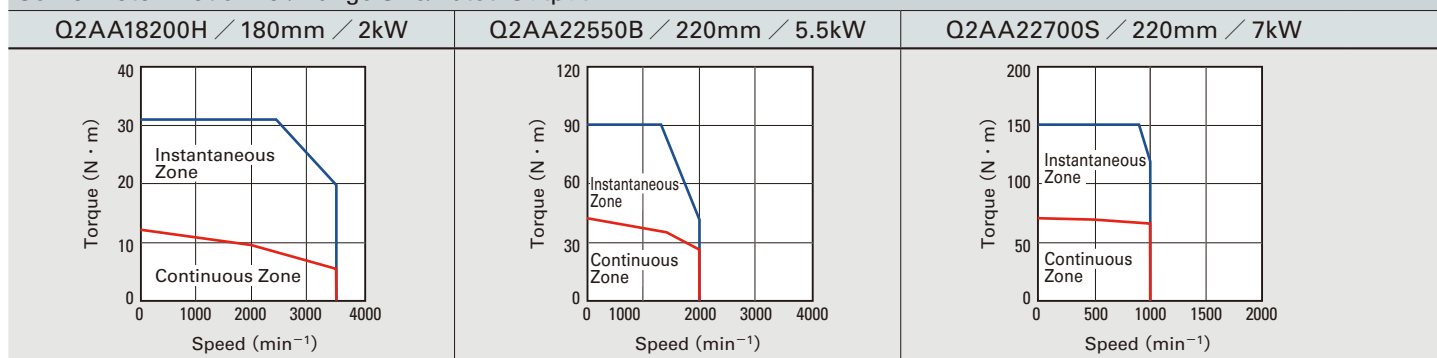



RS2A30A □		Servo Amplifier Model No.			
Q2AA2211KV 《220mm sq.》	Q2AA2215KV 《220mm sq.》	Servo Motor Model No. and Flange Size			
		Unit	Symbol	Status	
11	15	kW	P _R	★	Rated Output
1500		min ⁻¹	N _R	★	Rated Speed
2000		min ⁻¹	N _{max}	★	Maximum Speed
70	95.5	N·m	T _R	★	Rated Torque
80	95.5	N·m	T _S	★	Continuous Stall Torque
176	215	N·m	T _P	★	Peak Stall Torque
60	66	Arms	I _R	★	Rated Armature Current
66	66	Arms	I _S	★	Armature Stall Current
155	157	Arms	I _P	★	Peak Armature Stall Current
1.29	1.54	N·m/Arms	K _T	☆	Torque Constant
45.1	53.6	mV/min ⁻¹	K _{Eφ}	☆	Voltage Constant for each Phase
0.015	0.016	Ω	R _φ	☆	Phase Resistance
260	360	kW/s	Q _R	★	Rated Power Rate
33	33	ms	t _e	☆	Electrical Time Constant
0.50	0.52	ms	t _m	☆	Mechanical Time Constant (Not including Encoder)
186	255	×10 ⁻⁴ kg·m ² (GD ² /4)	J _M		Roter Moment of Inertia ^{※1}
58	70	kg	W _E		Servo Motor Mass ^{※1}
90	90	N·m	T _B		Brake Static Friction Torque
DC90V / DC24V ± 10%		V	V _B		Brake Rated Voltage
0.44 / 1.7		A	I _B		Brake Rated Current
24		×10 ⁻⁴ kg·m ² (GD ² /4)	J _B		Roter Moment of Inertia (Brake)
11		kg	W		Brake Mass
Operating Temperature: 0 to 40°C, Relative Humidity: 90% maximum, no condensation					Servo Motor Operating Temp, Rel.Humidity
15.7	21.4	kVA			Servo amplifier power supply capacity (rating)
Yes					CE and UL approved servo motors ^{※4}
IP67					Servo motor protection code
t30 × 610mm sq.					Size of aluminum plates for heat radiation during measurement

Servo motor Model No./Flange Size/Rated Output

Q2AA2211KV / 220mm / 11kW

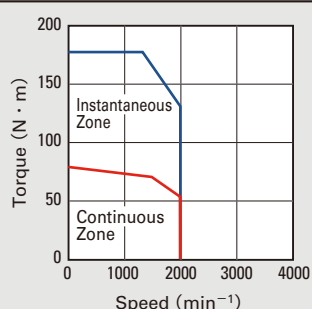

Q2AA2215KV / 220mm / 15kW

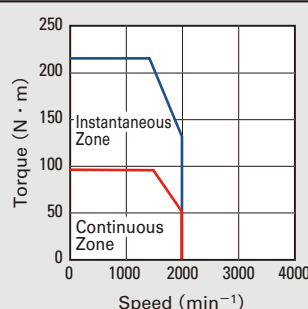

Specification



Servo Amplifier +



R1 Servo Motor High Power Rate (Low Inertia)

input voltage **AC200V**

Power supply range AC170V to AC253V

Servo Amplifier Model No.				RS2A30A □	
Servo Motor Model No. and Flange Size				R1AA18550H 《180mm sq.》	R1AA18750H 《180mm sq.》
	Status	Symbol	Unit		
Rated Output	★	P _R	kW	5.5	7.5
Rated Speed	★	N _R	min ⁻¹	1500	1500
Maximum Speed	★	N _{max}	min ⁻¹	3000	3000
Rated Torque	★	T _R	N·m	35	48
Continuous Stall Torque	★	T _S	N·m	37	48
Peak Stall Torque	★	T _P	N·m	110	135
Rated Armature Current	★	I _R	Arms	46	54.0
Armature Stall Current	★	I _S	Arms	47	53.0
Peak Armature Stall Current	★	I _P	Arms	140	155
Torque Constant	☆	K _T	N·m/Arms	0.86	0.98
Voltage Constant for each Phase	☆	K _{Eφ}	mV/min ⁻¹	30	34.1
Phase Resistance	☆	R _φ	Ω	0.031	0.025
Rated Power Rate	★	Q _R	kW/s	370	550
Electrical Time Constant	☆	t _e	ms	18	21
Mechanical Time Constant (Not including Encoder)	☆	t _m	ms	0.42	0.33
Roter Moment of Inertia ※ 1		J _M	×10 ⁻⁴ kg·m ² (GD ² /4)	33	42
Servo Motor Mass ※ 1		W _E	kg	27	39
Brake Static Friction Torque		T _B	N·m	42 MIN.	54.9 MIN.
Brake Rated Voltage		V _B	V	DC90V / DC24V ± 10%	
Brake Rated Current		I _B	A	0.27 / 1.0	0.37 / 1.4
Roter Moment of Inertia (Brake)		J _B	×10 ⁻⁴ kg·m ² (GD ² /4)	5.1	4.5
Brake Mass		W	kg	2.8	4.5
Servo Motor Operating Temp, Rel.Humidity				Operating Temperature: 0 to 40°C, Relative Humidity: 90% maximum, no condensation	
Cooling fan		P _F	W	39/33 AC200V±10% Single-phase 50Hz/60Hz	
Servo amplifier power supply capacity (rating)			kVA	9.3	11.6
CE and UL approved servo motors ※ 4				Under preparation	
Servo motor protection code				IP65(not include cooling fan)	
Size of aluminum plates for heat radiation during measurement				t20 × 540mm sq.	

※ 1 Including wire-saving incremental encoder.

For the servo amplifier weight, see page 51 and 52.

※ 2 Items with ★ indicate values after temperature rise saturation when installed on the Sanyo specified heat sink and used with a standard servo amplifier (with 3 phase AC200V input). The values are the typical values.

※ 3 ☆ :Indicates a typical value when the winding temperature is 20°C .

※ 4 Our standard servo amplifiers are CE and UL approved.

Speed-Torque Characteristics

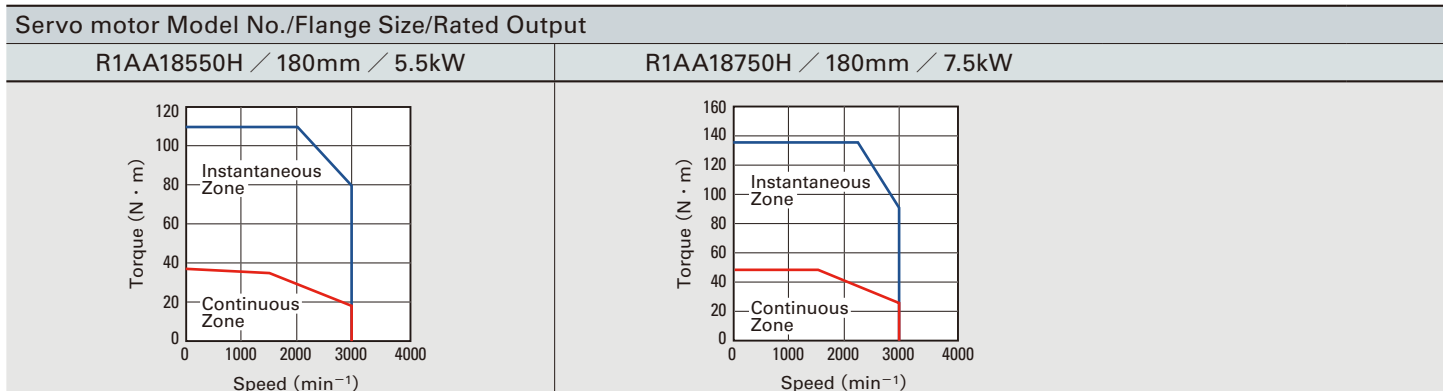



RS2A30A □		Servo Amplifier Model No.			
R1AA1811KR 《180mm sq.》	R1AA1815KB 《180mm sq.》	Servo Motor Model No. and Flange Size			
		Unit	Symbol	Status	
11	15	kW	PR	★	Rated Output
1500	1500	min ⁻¹	NR	★	Rated Speed
2500	2000	min ⁻¹	N _{max}	★	Maximum Speed
70	95.5	N·m	TR	★	Rated Torque
70	95.5	N·m	TS	★	Continuous Stall Torque
195	230	N·m	TP	★	Peak Stall Torque
55.0	60.0	Arms	IR	★	Rated Armature Current
54.0	58.0	Arms	IS	★	Armature Stall Current
155	155	Arms	IP	★	Peak Armature Stall Current
1.4	1.77	N·m/Arms	KT	☆	Torque Constant
48.7	61.6	mV/min ⁻¹	KEφ	☆	Voltage Constant for each Phase
0.033	0.033	Ω	Rφ	☆	Phase Resistance
770	1060	kW/s	QR	★	Rated Power Rate
22	25	ms	te	☆	Electrical Time Constant
0.32	0.27	ms	tm	☆	Mechanical Time Constant (Not including Encoder)
64	86	×10 ⁻⁴ kg·m ² (GD ² /4)	JM		Roter Moment of Inertia ※ 1
52	64	kg	WE		Servo Motor Mass ※ 1
75 MIN.	120 MIN.	N·m	TB		Brake Static Friction Torque
DC24V ± 10%		V	VB		Brake Rated Voltage
1.5	1.9	A	IB		Brake Rated Current
8.0	9.7	×10 ⁻⁴ kg·m ² (GD ² /4)	JB		Roter Moment of Inertia (Brake)
7.1	8.9	kg	W		Brake Mass
Operating Temperature: 0 to 40°C, Relative Humidity: 90% maximum, no condensation					Servo Motor Operating Temp, Rel.Humidity
		Pf	W		Cooling fan
16	21.4	kVA			Servo amplifier power supply capacity (rating)
Under preparation					CE and UL approved servo motors ※ 4
IP65(not include cooling fan)					Servo motor protection code
t20 × 540mm sq.					Size of aluminum plates for heat radiation during measurement

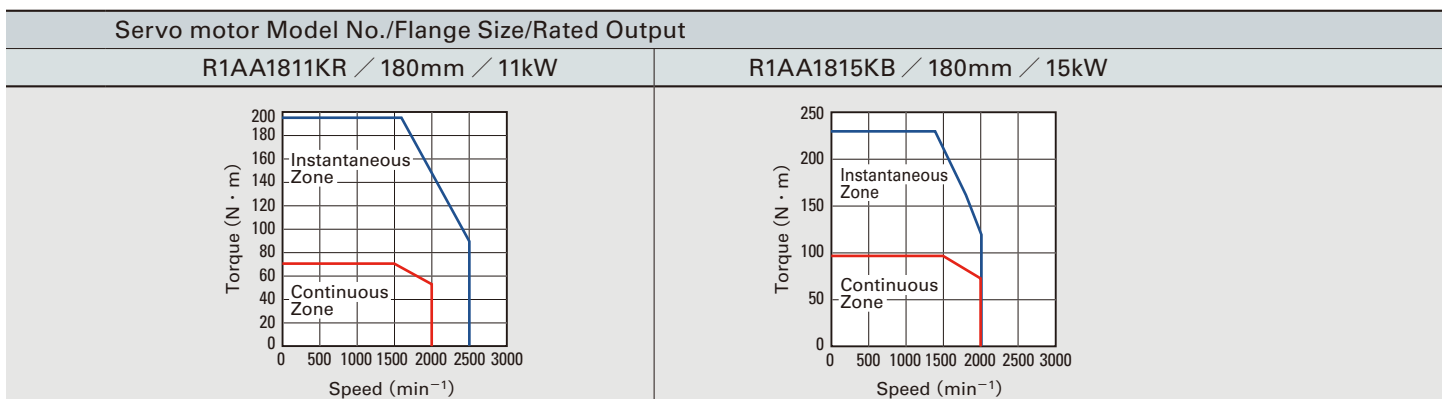

Specification



Servo Amplifier +  **Q1** Servo Motor High Power Rate (Low Inertia)

input voltage **AC200V**

Power supply range AC170V to AC253V

Servo Amplifier Model No.				RS2A05A□		RS2A10A□
Servo Motor Model No. and Flange Size				Q1AA10100D 《100mm sq.》	Q1AA10150D 《100mm sq.》	Q1AA10200D 《100mm sq.》
	Status	Symbol	Unit			
Rated Output	★	P _R	kW	1	1.5	2
Rated Speed	★	N _R	min ⁻¹	3000		
Maximum Speed	★	N _{max}	min ⁻¹	5000	4500	5000
Rated Torque	★	T _R	N·m	3.19	4.79	6.37
Continuous Stall Torque	★	T _S	N·m	3.92	4.9	7.36
Peak Stall Torque	★	T _P	N·m	10.5	14.7	19.6
Rated Armature Current	★	I _R	Arms	6.5	8.2	15.9
Armature Stall Current	★	I _S	Arms	7.8	8.2	18
Peak Armature Stall Current	★	I _P	Arms	24.5	26.5	55
Torque Constant	☆	K _T	N·m/Arms	0.55	0.705	0.47
Voltage Constant for each Phase	☆	K _{Eφ}	mV/min ⁻¹	19.3	24.6	16.4
Phase Resistance	☆	R _φ	Ω	0.34	0.272	0.086
Rated Power Rate	★	Q _R	kW/s	78.9	143	189
Electrical Time Constant	☆	t _e	ms	7.6	11.4	12.1
Mechanical Time Constant (Not including Encoder)	☆	t _m	ms	0.43	0.26	0.25
Rotor Moment of Inertia ※ 1		J _M	×10 ⁻⁴ kg·m ² (GD ² /4)	1.29	1.61	2.15
Servo Motor Mass ※ 1		W _E	kg	5.4	6.5	8.7
Brake Static Friction Torque		T _B	N·m	3.92	9.8	9.8
Brake Rated Voltage		V _B	V	DC90V / DC24V ± 10%		
Brake Rated Current		I _B	A	0.2 / 0.61	0.2 / 0.83	0.2 / 0.83
Rotor Moment of Inertia (Brake)		J _B	×10 ⁻⁴ kg·m ² (GD ² /4)	0.15	0.4	0.4
Brake Mass		W	kg	1.3	1.5	1.5
Servo Motor Operating Temp, Rel.Humidity				Operating Temperature: 0 to 40°C, Relative Humidity: 90% maximum, no condensation		
Servo amplifier power supply capacity (rating)			kVA	2.5	3.0	4.0
CE and UL approved servo motors ※ 4				Yes		
Servo motor protection code				IP67		
Size of aluminum plates for heat radiation during measurement				t20 × 400mm sq.		t20 × 470mm sq.

※ 1 Including wire-saving incremental encoder.

For the servo amplifier weight, see page 51 and 52.

※ 2 Items with ★ and speed - torque characteristics indicate values after temperature rise saturation when used with a standard servo amplifier. The values are the typical values.

※ 3 ☆ :Indicates a typical value when the winding temperature is 20°C .

※ 4 Our standard servo amplifiers are CE and UL approved.

Speed-Torque Characteristics

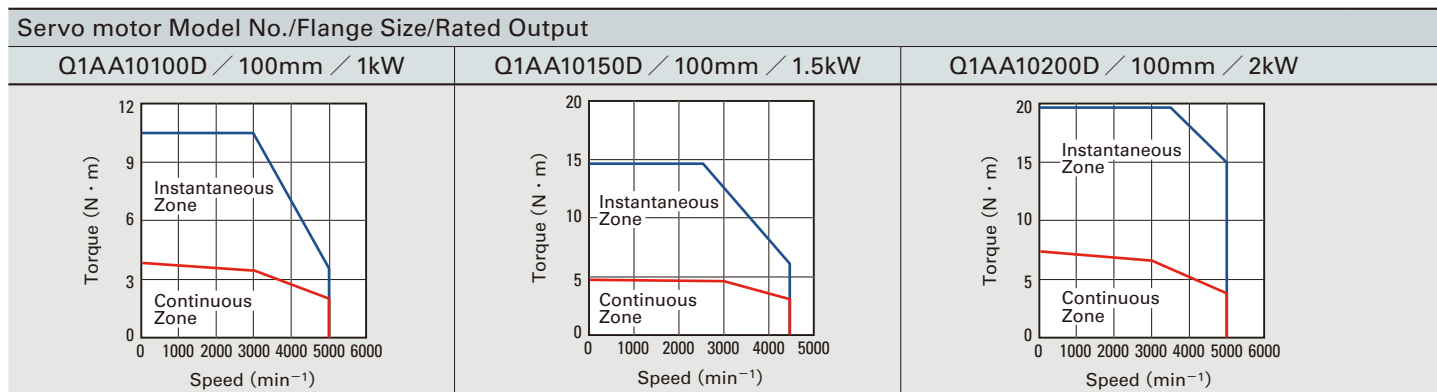

RS2A10A □	RS2A05A □	RS2A10A □	Servo Amplifier Model No.			
Q1AA10250D 《100mm sq.》	Q1AA12100D 《120mm sq.》	Q1AA12200D 《120mm sq.》	Servo Motor Model No. and Flange Size			
2.5	1	2	Unit	Symbol	Status	
	3000		kW	P _R	★	Rated Output
	5000		min ⁻¹	N _R	★	Rated Speed
			min ⁻¹	N _{max}	★	Maximum Speed
7.97	3.19	6.37	N·m	T _R	★	Rated Torque
8.82	3.92	7.36	N·m	T _S	★	Continuous Stall Torque
24.4	11	21	N·m	T _P	★	Peak Stall Torque
16.6	6.2	14.3	Arms	I _R	★	Rated Armature Current
17.2	7.5	16.2	Arms	I _S	★	Armature Stall Current
55	24.5	53	Arms	I _P	★	Peak Armature Stall Current
0.587	0.587	0.5	N·m/Arms	K _T	☆	Torque Constant
20.5	20.2	17.6	mV/min ⁻¹	K _{Eφ}	☆	Voltage Constant for each Phase
0.104	0.19	0.06	Ω	R _φ	☆	Phase Resistance
240	45.2	93	kW/s	Q _R	★	Rated Power Rate
13	13	20	ms	t _e	☆	Electrical Time Constant
0.24	0.38	0.31	ms	t _m	☆	Mechanical Time Constant (Not including Encoder)
2.65	2.25	4.37	×10 ⁻⁴ kg·m ² (GD ² /4)	J _M		Roter Moment of Inertia ^{※ 1}
9.4	5.4	8.7	kg	W _E		Servo Motor Mass ^{※ 1}
9.8	9.0	9.0	N·m	T _B		Brake Static Friction Torque
DC90V / DC24V ± 10%			V	V _B		Brake Rated Voltage
0.2 / 0.83	0.25 / 0.86		A	I _B		Brake Rated Current
0.4	0.5	0.5	×10 ⁻⁴ kg·m ² (GD ² /4)	J _B		Roter Moment of Inertia (Brake)
1.5	1.5	1.5	kg	W		Brake Mass
Operating Temperature: 0 to 40°C, Relative Humidity: 90% maximum, no condensation						Servo Motor Operating Temp, Rel.Humidity
4.2	2.5	4.0	kVA			Servo amplifier power supply capacity (rating)
Yes						CE and UL approved servo motors ^{※ 4}
IP67						Servo motor protection code
t20 × 470mm sq.	t20 × 400mm sq.	t20 × 470mm sq.				Size of aluminum plates for heat radiation during measurement

Servo motor Model No./Flange Size/Rated Output

Q1AA10250D / 100mm / 2.5kW

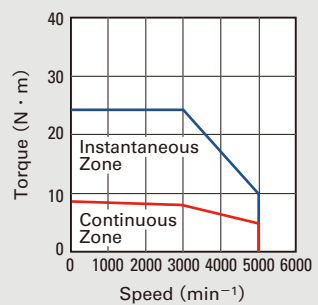

Q1AA12100D / 120mm / 1kW

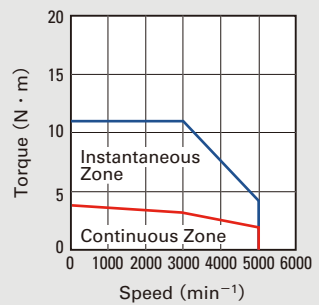

Q1AA12200D / 120mm / 2kW

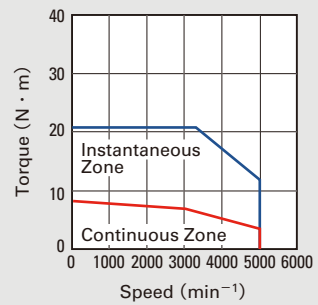

Specification



Servo Amplifier



Q1

Servo Motor

High Power Rate (Low Inertia)

input voltage **AC200V**

Power supply range AC170V to AC253V

Servo Amplifier Model No.				RS2A10A □	
Servo Motor Model No. and Flange Size				Q1AA12300D 《120mm sq.》	Q1AA13300D 《130mm sq.》
	Status	Symbol	Unit		
Rated Output	★	P _R	kW	3	
Rated Speed	★	N _R	min ⁻¹	3000	
Maximum Speed	★	N _{max}	min ⁻¹	5000	4500
Rated Torque	★	T _R	N·m	9.6	9.5
Continuous Stall Torque	★	T _S	N·m	11	10.8
Peak Stall Torque	★	T _P	N·m	31	28.4
Rated Armature Current	★	I _R	Arms	16.2	16.7
Armature Stall Current	★	I _S	Arms	17.3	17.6
Peak Armature Stall Current	★	I _P	Arms	55	55
Torque Constant	☆	K _T	N·m/Arms	0.73	0.693
Voltage Constant for each Phase	☆	K _{Eφ}	mV/min ⁻¹	25.4	24.2
Phase Resistance	☆	R _φ	Ω	0.082	0.087
Rated Power Rate	★	Q _R	kW/s	143	184
Electrical Time Constant	☆	t _e	ms	13.9	17.9
Mechanical Time Constant (Not including Encoder)	☆	t _m	ms	0.3	0.27
Rotor Moment of Inertia ※ 1		J _M	×10 ⁻⁴ kg·m ² (GD ² /4)	6.4	4.92
Servo Motor Mass ※ 1		W _E	kg	11.4	
Brake Static Friction Torque		T _B	N·m	11.8	
Brake Rated Voltage		V _B	V	DC90V / DC24V ± 10%	
Brake Rated Current		I _B	A	0.28 / 1.0	
Rotor Moment of Inertia (Brake)		J _B	×10 ⁻⁴ kg·m ² (GD ² /4)	0.5	
Brake Mass		W	kg	1.7	
Servo Motor Operating Temp, Rel.Humidity				Operating Temperature: 0 to 40°C, Relative Humidity: 90% maximum, no condensation	
Servo amplifier power supply capacity (rating)			kVA	5.0	5.0
CE and UL approved servo motors ※ 4				Yes	
Servo motor protection code				IP67	
Size of aluminum plates for heat radiation during measurement				t20 × 470mm sq.	

※ 1 Including wire-saving incremental encoder.

※ 3 ☆ :Indicates a typical value when the winding temperature is 20°C .

※ 2 Items with ★ and speed - torque characteristics indicate values after temperature rise saturation when used with a standard servo amplifier. The values are the typical values.

※ 4 Our standard servo amplifiers are CE and UL approved.

Speed-Torque Characteristics

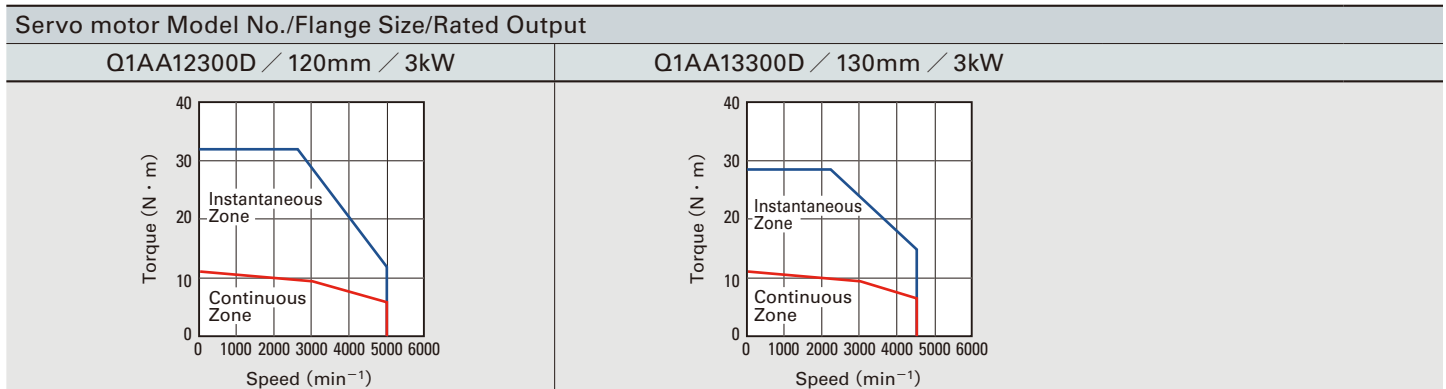



RS2A15A □		Servo Amplifier Model No.			
Q1AA13400D 《130mm sq.》	Q1AA13500D 《130mm sq.》	Servo Motor Model No. and Flange Size			
		Unit	Symbol	Status	
4	5	kW	PR	★	Rated Output
3000		min ⁻¹	NR	★	Rated Speed
4500		min ⁻¹	N _{max}	★	Maximum Speed
12.7	15.7	N·m	TR	★	Rated Torque
14.7	18.1	N·m	TS	★	Continuous Stall Torque
39.2	47.6	N·m	TP	★	Peak Stall Torque
23.4	25.8	Arms	IR	★	Rated Armature Current
26.4	27.5	Arms	IS	★	Armature Stall Current
83	83	Arms	IP	★	Peak Armature Stall Current
0.612	0.724	N·m/Arms	KT	☆	Torque Constant
21.4	25.3	mV/min ⁻¹	KEφ	☆	Voltage Constant for each Phase
0.048	0.0461	Ω	Rφ	☆	Phase Resistance
251	291	kW/s	QR	★	Rated Power Rate
19.2	20.8	ms	te	☆	Electrical Time Constant
0.25	0.22	ms	tm	☆	Mechanical Time Constant (Not including Encoder)
6.43	8.47	×10 ⁻⁴ kg·m ² (GD ² /4)	JM		Roter Moment of Inertia ^{※1}
14.4	16	kg	WE		Servo Motor Mass ^{※1}
19.6		N·m	TB		Brake Static Friction Torque
DC90V / DC24V ± 10%		V	VB		Brake Rated Voltage
0.25 / 0.95		A	IB		Brake Rated Current
0.58		×10 ⁻⁴ kg·m ² (GD ² /4)	JB		Roter Moment of Inertia (Brake)
2.2		kg	W		Brake Mass
Operating Temperature: 0 to 40°C, Relative Humidity: 90% maximum, no condensation					Servo Motor Operating Temp, Rel.Humidity
6.7	8.3	kVA			Servo amplifier power supply capacity (rating)
Yes					CE and UL approved servo motors ^{※4}
IP67					Servo motor protection code
t20 × 470mm sq.	t20 × 540mm sq.				Size of aluminum plates for heat radiation during measurement

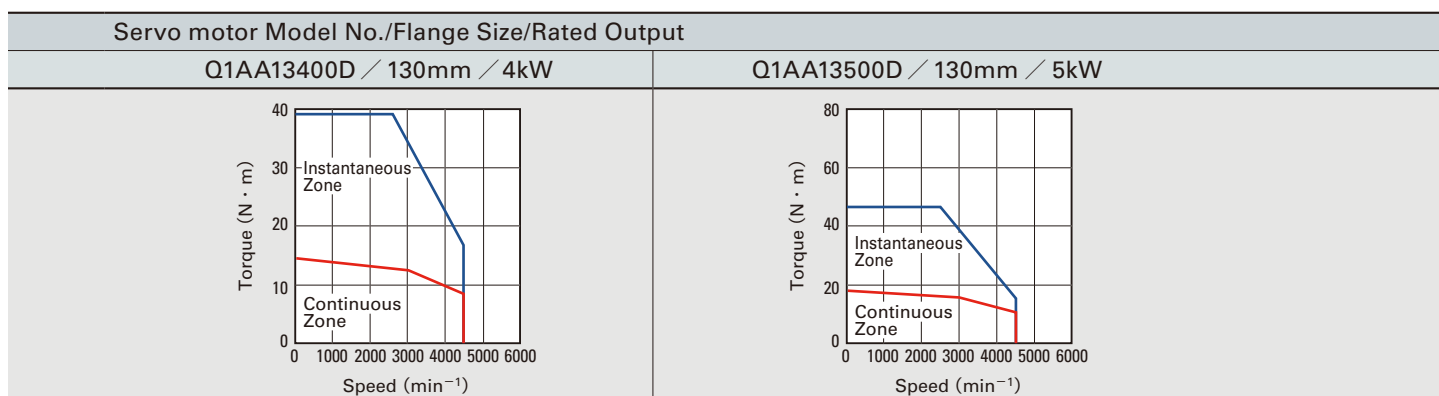

Encoder Wiring Diagram

Serial Encoder

- Battery backup type absolute encoder [PA035C]
- Absolute encoder for incremental system [PA035S]
- Batteryless absolute encoder [RA035C, HA062]

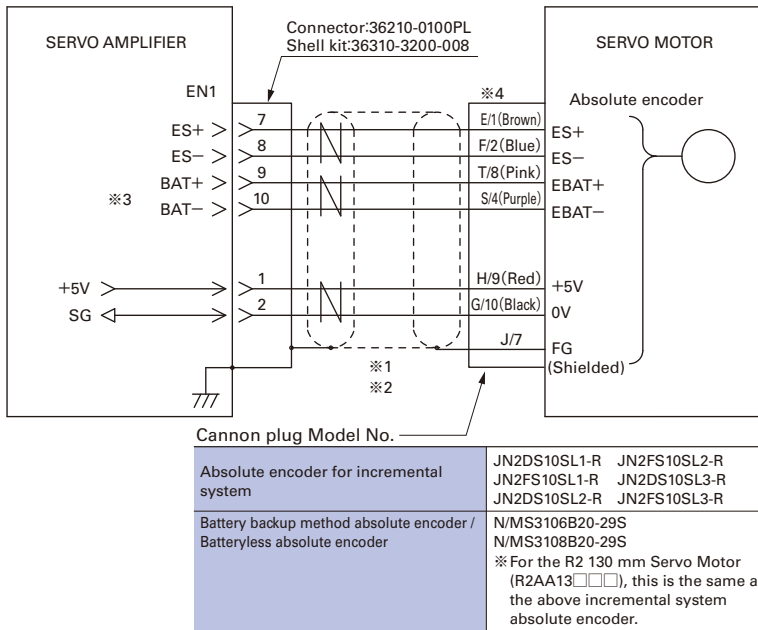

- ※1 Use a twisted-pair shielded cable.
- ※2 The maximum cable lengths under the conductor size of the power supply cable (5V,SG).

Conductor size		Conductor resistance	Length
AWG	SQ (mm ²)	(Ω/km) ※20°C	(m)
26	0.15	150 or less	5
24	0.2	100 or less	10
22	0.3	60 or less	15
20	0.5	40 or less	25
18	0.75	25 or less	40

Conductor resistance is different by conductor specifications.

- ※3 When the absolute encoder for incremental system or batteryless absolute encoder is used, battery lines (EBAT+, EBAT-) are not required.
- ※4 Lead wire colors are indicated in parentheses. The pin numbers of cannon plug type: See the following table.

Encoder	ES+	ES-	EBAT+	EBAT-	+5V	0V	FG
Battery backup method Absolute encoder	E/1	F/2	T/8	S/4	H/9	G/10	J/7
Absolute encoder for incremental system	1	2	—	—	9	10	7
Batteryless absolute encoder	E	F	—	—	H	G	J

Pulse Encoder

- Wire-saving incremental encoder

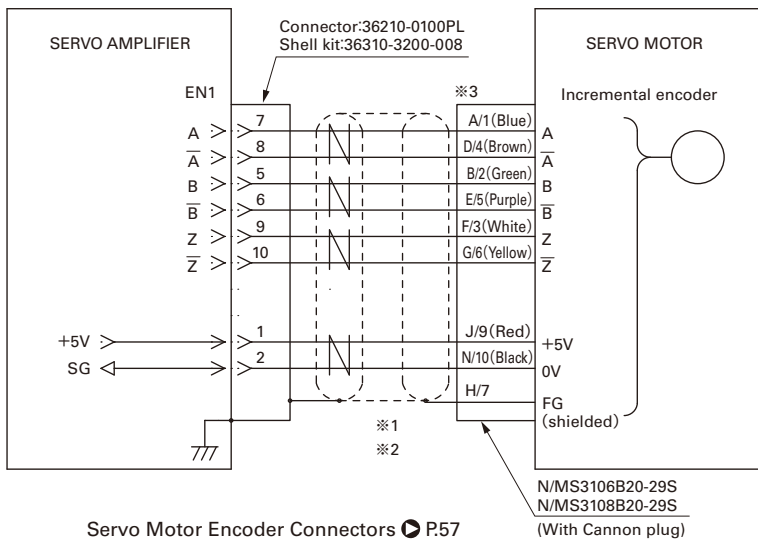

- ※1 Use a twisted-pair shielded cable.
- ※2 The maximum cable lengths under the conductor size of the power supply cable (5V,SG).

Conductor size		Conductor resistance	Length
AWG	SQ (mm ²)	(Ω/km) ※20°C	(m)
26	0.15	150 or less	5
24	0.2	100 or less	10
22	0.3	60 or less	15
20	0.5	40 or less	25
18	0.75	25 or less	40

Conductor resistance is different by conductor specifications.

- ※3 Letters indicate cannon plug pins. Lead wire colors are indicated in parentheses.

Analog/Pulse input type (NPN output)

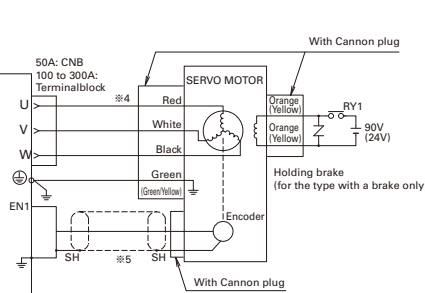
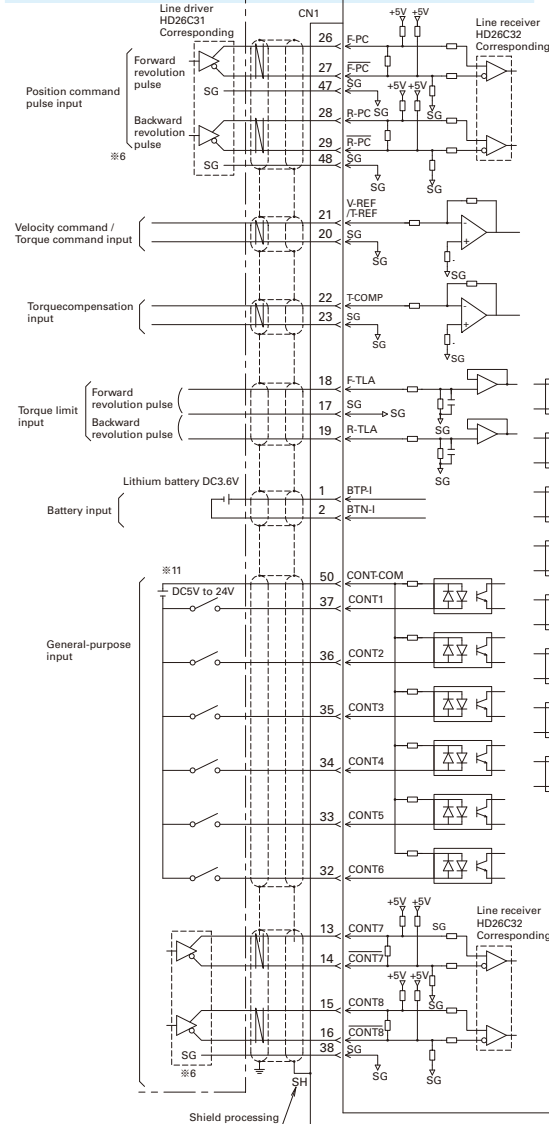
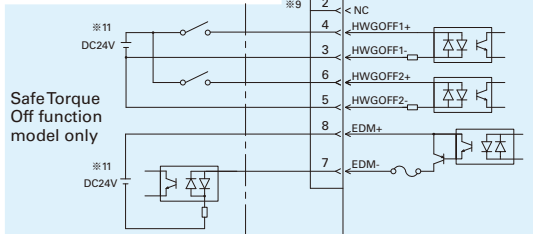
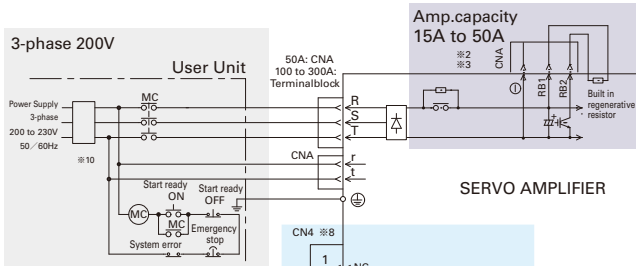
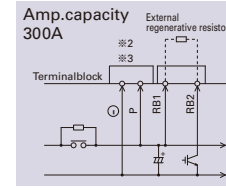
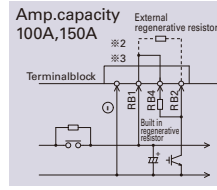
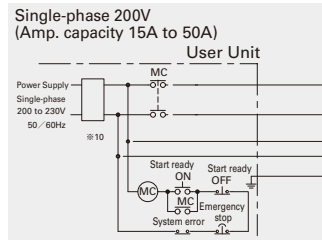
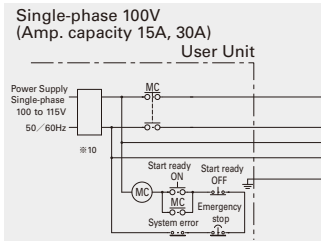

Connector No.	Name	Housing, plug, shell
CNA 15A to 50A	Control power, main power input connector	MSTB2.5/8-STF-5.08LUB
CNA 100A, 150A, 300A	Control power input connector	MSTBT2.5/2-STF-5.08
CNB 15A to 50A	Servo motor power connector	MSTBT2.5/3-STF-5.08
CN1	Connector for host device input / output signals	Plug:10150-3000PE Shell kit:36310-3200-008
EN1	Encoder signal connector	Connector:36210-0100PL Shell kit:36310-3200-008
CN4	Safe Torque Off function connector	For short-circuit:2040978-1 For customer wiring:2013595-3

- ※1 For the parts marked , use a twisted pair shielded cable.
- ※2 AMP. capacity 15A, 30A, 50A
When using an external regenerative resistor, connect it between RB1 and 2. If RB1 and 2 are connected to the internal amplifier's resistor, or if a shorting bar is connected between RB1 and 4, first disconnect them.
AMP. capacity 100A, 150A
When using internal regenerative resistor, connect short-circuit bar between RB1 and RB4 terminals. When using external regenerative resistor, connect it between RB1 and RB2 terminals after removing short-circuit bar between RB1 and RB4 terminals.
AMP. capacity 300A
Connect external regenerative resistor between RB1 and RB2 terminals.
- ※3 The ⊖ terminal and the P terminal are for maintenance (high-voltage circuit). So, do not wire this terminal.
- ※4 Motor connection differs to the motor specifications. The indications of red, white, black, green and orange apply when the motor power and brake lines are the lead type. When they are the cannon plug type, connect them according to the motor specification. Refer to "Pin Assignment Symbols" on page 58.
- ※5 Refer to "encoder connection diagram" on page 41 for the wiring for the connector for the encoder connection.
- ※6 Please be sure to connect SG(signal ground) between equipment with servo amplifier when you use a difference input signal.
- ※7 R, S, T, t, r, ⊖, P, DL1, DL2, RB1, RB2, RB4 (100A, 150A only), U, V, W are high-voltage circuits, all other lines are low-voltage. Ensure sufficient distance between the high- and low-voltage circuits.
- ※8 CN4 is a connector for safety function signals. To turn the servo motor power ON, a safety device must be connected and the wiring to activate the safety function must be done. When not using the safety function, use the connector (P.N : AL-00718251-01) of an option inserted into the CN4.
- ※9 Nothing should connect with CN4-1 and 2pin.
- ※10 It is recommend to use a ground fault interrupter conforming to the UL, IEC and EN standards.
- ※11 Power should be supplies by the user.

EtherCAT interface type

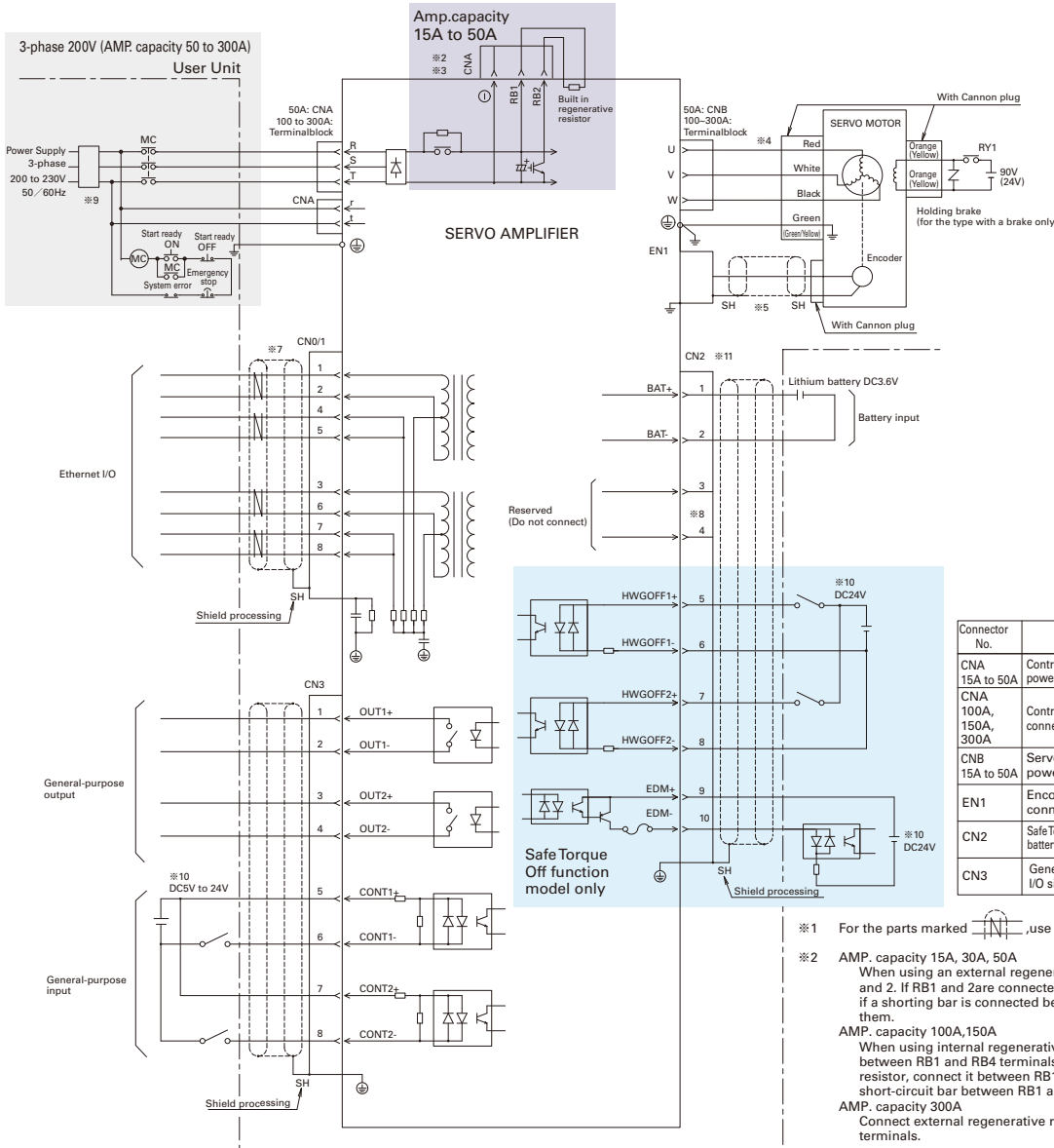
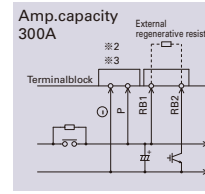
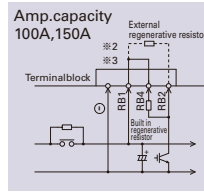
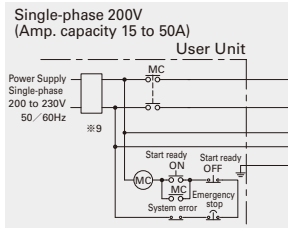
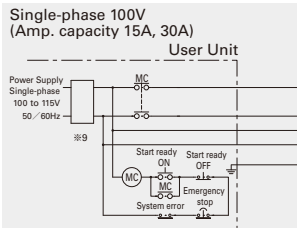

Connector No.	Name	Housing, plug, shell
CNA 15A to 50A	Control power, main power input connector	MSTB2.5/8-STF-5.08LUB
CNA 100A, 150A, 300A	Control power input connector	MSTBT2.5/2-STF-5.08
CNB 15A to 50A	Servo motor power connector	MSTBT2.5/3-STF-5.08
EN1	Encoder signal connector	Connector:36210-0100PL Shell kit:36310-3200-008
CN2	Safe Torque Off function, battery power connector	MUF-PK10K-X
CN3	General-purpose I/O signal connector	2013595-3

- ※1 For the parts marked , use a twisted pair shielded cable.
- ※2 **AMP. capacity 15A, 30A, 50A**
When using an external regenerative resistor, connect it between RB1 and 2. If RB1 and 2 are connected to the internal amplifier's resistor, or if a shorting bar is connected between RB1 and 4, first disconnect them.
- AMP. capacity 100A, 150A**
When using internal regenerative resistor, connect short-circuit bar between RB1 and RB4 terminals. When using external regenerative resistor, connect it between RB1 and RB2 terminals after removing short-circuit bar between RB1 and RB4 terminals.
- AMP. capacity 300A**
Connect external regenerative resistor between RB1 and RB2 terminals.
- ※3 The ⊖ terminal and the P terminal are for maintenance (high voltage circuit). So, do not wire this terminal.
- ※4 Motor connection differs to the motor specifications. The indications of red, white, black, green and orange apply when the motor power and brake lines are the lead type. when they are the cannon plug type, connect them according to the motor specification. Refer to "Pin Assignment Symbols" on page 58.
- ※5 Refer to "encoder connection diagram" on page 41 for the wiring for the connector for the encoder connection.
- ※6 R, S, T, r, r, ⊖, P, DL1, DL2, RB1, RB2, RB4 (100A, 150A only), U, V, W are high-voltage circuits, all other lines are low-voltage. Ensure sufficient distance between the high- and low-voltage circuits.
- ※7 Use a TIA category 5e or better shielded twisted pair (STP) cable.
- ※8 Nothing should connect with CN2-3 and 4pin.
- ※9 It is recommend to use a ground fault interrupter conforming to the UL, IEC and EN standards. Do not wire the S phase for a single-phase power amplifier.
- ※10 Power should be supplies by the user.
- ※11 CN2 is a Safe Torque Off function connector. If it is not connected to the safety device to enable the Safe Torque Off function to work, the servo does not turn on (the motor is not energized).

40mm sq. to 100mm sq. R2 Servo Motor Series

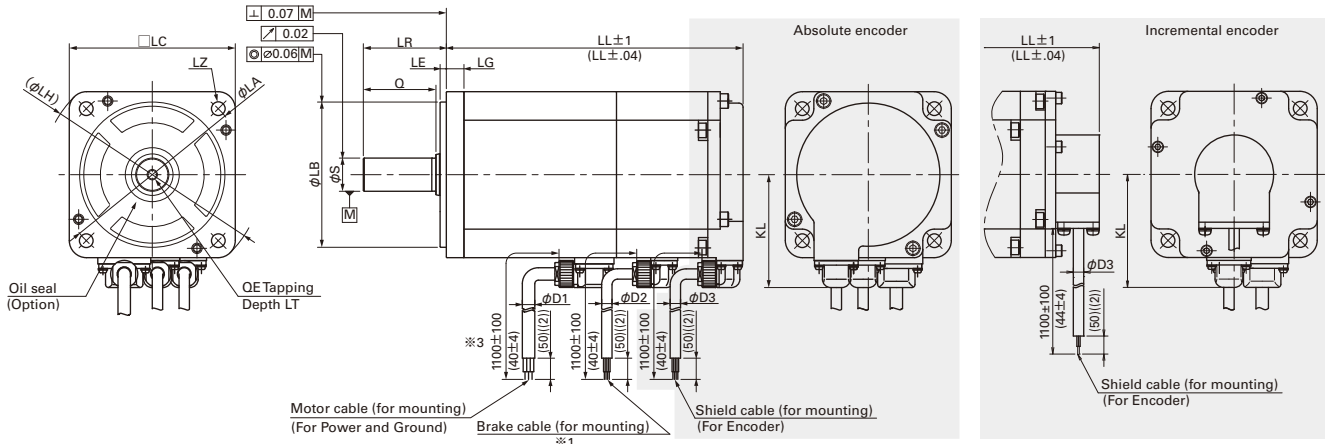

※Dimensions with brake but without relay cable connector

MODEL	Battery backup method absolute encoder, Absolute encoder for incremental system				Incremental encoder				LG	KL	LA	LB	LE
	W/out oil seal		With oil seal		W/out oil seal		With oil seal						
	W/out brake	With brake	W/out brake	With brake	W/out brake	With brake	W/out brake	With brake					
	LL	LL	LL	LL	LL	LL	LL	LL					
R2□A04003	51.5 (2.06)	87.5 (2.28)	56.5 (2.26)	92.5 (3.7)	63.5 (2.54)	99.5 (3.98)	68.5 (2.74)	104.5 (4.18)	5 (.2)	35.4 (1.416)	46 (1.84)	0 30-0.021 0 (30 -.00084)	2.5 (.1)
R2□A04005	56.5 (2.26)	92.5 (3.7)	61.5 (2.46)	97.5 (3.9)	68.5 (2.74)	104.5 (4.18)	73.5 (2.94)	109.5 (4.38)					
R2EA04008	72 (2.8)	108 (4.32)	77 (3.08)	113 (4.52)	84 (3.36)	120 (4.8)	89 (3.56)	125 (5)					
R2AA04010													
R2□A06010	58.5 (2.34)	82.5 (3.3)	65.5 (2.62)	89.5 (3.58)	78.2 (3.128)	106.2 (4.248)	85.2 (3.408)	113.2 (4.528)	6 (.24)	44.6 (1.784)	70 (2.8)	0 50-0.025 0 (2 -.001)	3 (.12)
R2□A06020	69.5 (2.78)	97.5 (3.9)	76.5 (3.06)	104.5 (4.18)	89.2 (3.568)	117.2 (4.688)	96.2 (3.848)	124.2 (4.968)					
R2AA06040	95.5 (3.82)	123.5 (4.94)	102.5 (4.1)	130.5 (5.22)	115.2 (4.608)	143.2 (5.728)	122.2 (4.888)	150.2 (6.008)					
R2AA08020	66.3 (2.652)	102 (4.08)	73.3 (2.932)	109 (4.36)	90 (3.6)	122.7 (4.908)	97 (3.88)	129.7 (5.188)	8 (.32)	54.4 (2.176)	90 (3.6)	0 70-0.030 0 (2.8 -.012)	
R2AA08040	78.3 (3.132)	114 (4.56)	85.3 (3.142)	121 (4.84)	102 (4.08)	134.7 (5.388)	109 (4.36)	141.7 (5.6799)					
R2AA08075	107.3 (4.292)	143 (5.72)	114.3 (4.572)	150 (6)	131 (5.24)	163.7 (6.548)	138 (5.52)	170.7 (6.8279)					
R2AAB8075	114.3 (4.499)	140.2 (5.519)	114.3 (4.572)	140.2 (5.519)	128.8 (5.07)	154.7 (6.09)	128.8 (5.07)	154.7 (6.09)	59.4 (2.376)	100 (4)	100 (4)	0 80-0.030 0 (3.2 -.0012)	
R2AAB8100	137 (5.48)	163 (6.52)	137 (5.48)	163 (6.52)	151.5 (6.06)	177.4 (7.096)	151.5 (6.06)	177.4 (7.096)					
R2AA10075	111.3 (4.452)	128.8 (5.152)	111.3 (4.452)	128.8 (5.152)	—	—	—	—					
R2AA10100	128.3 (5.132)	145.8 (5.832)	128.3 (5.132)	145.8 (5.832)	—	—	—	—	10 (.4)	66.8 (2.672)	115 (4.6)	0 95-0.035 0 (3.8 -.0014)	

MODEL	LH	LC	LZ	LR	S	Q	QE	LT	D1	D2	D3
R2□A04003	56 (2.24)	40 (1.6)	2-D4.5 (2-D.18)	25 (1)	0 6-0.008 (.24 -.00032)	20 (.8)	—	—			
R2□A04005					0 8-0.009 (.32 -.0003)						
R2EA04008					0 8-0.009 (.32 -.0003)						
R2AA04010					0 8-0.009 (.32 -.0003)						
R2□A06010	82 (3.28)	60 (2.4)	4-D5.5 (4-D.22)	25 (1)	0 8-0.009 (.32 -.0003)	25 (1)	M5	12 (.48)	6 (.23)	5 (.19)	5 (.19)
R2□A06020					0 14-0.011 (.55 -.0003)						
R2AA06040					0 14-0.011 (.55 -.0003)						
R2AA08020					0 16-0.011 (.56 -.0003)						
R2AA08040	108 (4.25)	80 (3.14)	4-D6.6 (4-D.264)	40 (1.57)	0 16-0.011 (.56 -.0003)	35 (1.4)	M5	12 (.48)			
R2AA08075					0 16-0.011 (.56 -.0003)						
R2AAB8075					0 16-0.011 (.56 -.0003)						
R2AAB8100					0 16-0.011 (.56 -.0003)						
R2AA10075	130 (5.11)	100 (3.93)	4-D5.5 (4-D.36)	45 (1.8)	0 22-0.013 (.88 -.0005)	40 (1.6)	M6	20 (.8)			
R2AA10100					0 22-0.013 (.88 -.0005)						

※1 Brake connectors (cables) are not supplied for models without brakes.
 ※2 A reduction in the rating might be needed if an oil seal and Brake is attached. Please consult with us about the details.
 ※3 The cable length of the motor with relay cable connector is 200±30mm. The connector is attached to the end of the cable.

For the following encoders, please make inquiries:
 • Resolver method batteryless absolute encoder [RA035C], High precision battery-less optical absolute encoder [HA062].

130mm sq.

R2 Servo Motor Series 0.5kW to 1.8kW

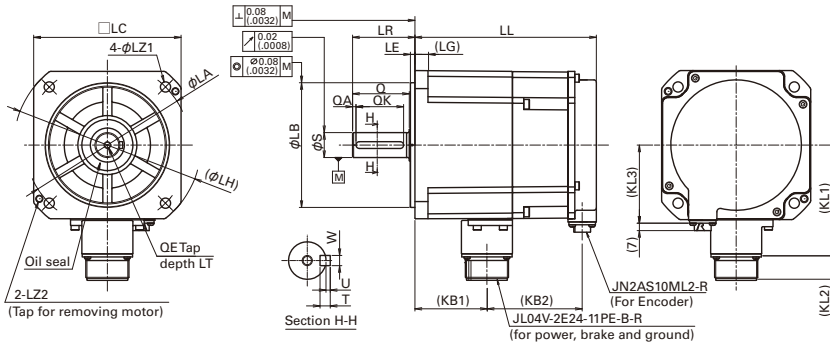

※Dimensions with the battery backup method absolute encoder and brake.

MODEL	Battery backup method absolute encoder, Absolute encoder for incremental system						Incremental encoder									
	Without brake			With brake			Without brake			With brake						
	LL	KB2	KL3	LL	KB2	KL3	LL	KB2	KL3	LL	KB2	KL3	LG	KL1	KL2	LA
R2AA13050	103 (4.12)			139.5 (5.58)	81 (3.24)		115.5 (4.62)			153.5 (6.14)	93 (3.72)					
R2AA13120	120.5 (4.82)	44 (1.76)	69 (2.76)	160 (6.4)	84 (3.36)	69 (2.76)	133 (5.32)	57 (2.28)	38 (1.52)	174 (6.96)	96 (3.84)	38 (1.52)	12 (.48)	98 (3.92)	21 (.84)	145 (5.8)
R2AA13180	138 (5.52)			179 (7.16)	86 (3.44)		150.5 (6.02)			192 (7.68)	96 (3.84)					

MODEL	LB	LE	LH	LC	LZ1	LZ2	LR	S	Q	QA	QK	W	T	U	KB1	QE	LT
R2AA13050	0							0				0			46 (1.84)		
R2AA13120	110 -0.035 0	4 (.16)	165 (6.6)	130 (5.2)	9 (.36)	M6	55 (2.2)	22 -0.013 0 (.88 -0.00052)	50 (2)	3 (.12)	42 (1.68)	6 -0.030 0 (.24 -0.0012)	6 (.24)	2.5 (.1)	M6	64 (2.56)	20 (.8)
R2AA13180	0							0				0			81 (3.24)		

For the following encoders, please make inquiries:

- Resolver method batteryless absolute encoder [RA035C], High precision battery-less optical absolute encoder [HA062].

130mm sq.

R2 Servo Motor Series 2kW

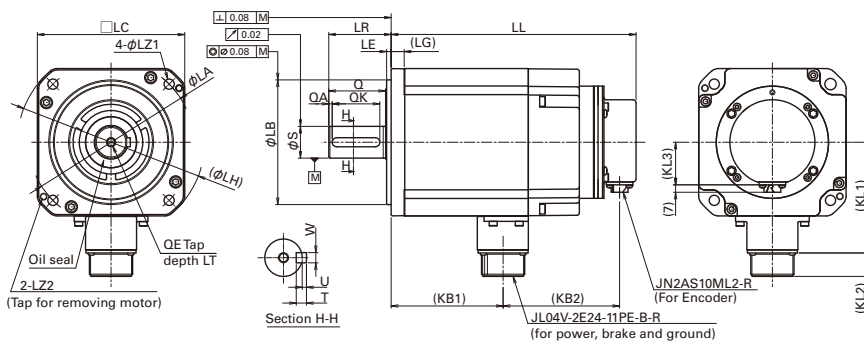

※Dimensions with the battery backup method absolute encoder and brake.

MODEL	Battery backup method absolute encoder, Absolute encoder for incremental system						Incremental encoder									
	Without brake			With brake			Without brake			With brake						
	LL	KB2	KL3	LL	KB2	KL3	LL	KB2	KL3	LL	KB2	KL3	LG	KL1	KL2	LA
R2AA13200	171 (6.84)	57 (2.28)	38 (1.52)	216 (8.64)	103 (4.12)	38 (1.52)	185 (7.4)	64 (2.56)	65 (2.6)	230 (9.2)	110 (4.4)	65 (2.6)	12 (.48)	98 (3.92)	21 (.84)	145 (5.8)

MODEL	LB	LE	LH	LC	LZ1	LZ2	LR	S	Q	QA	QK	W	T	U	KB1	QE	LT
R2AA13200	0							0				0					
R2AA13200	110 -0.035 0	4 (.16)	165 (6.6)	130 (5.2)	9 (.36)	M6	55 (2.2)	28 -0.013 0 (1.12 -0.00052)	50 (2)	3 (.12)	42 (1.68)	8 -0.036 0 (.32 -0.0014)	7 (.28)	3 (.12)	M8	99 (3.96)	25 (1)

For the following encoders, please make inquiries:

- Resolver method batteryless absolute encoder [RA035C], High precision battery-less optical absolute encoder [HA062].

180mm sq. R2 Servo Motor Series 3.5kW to 7.5kW

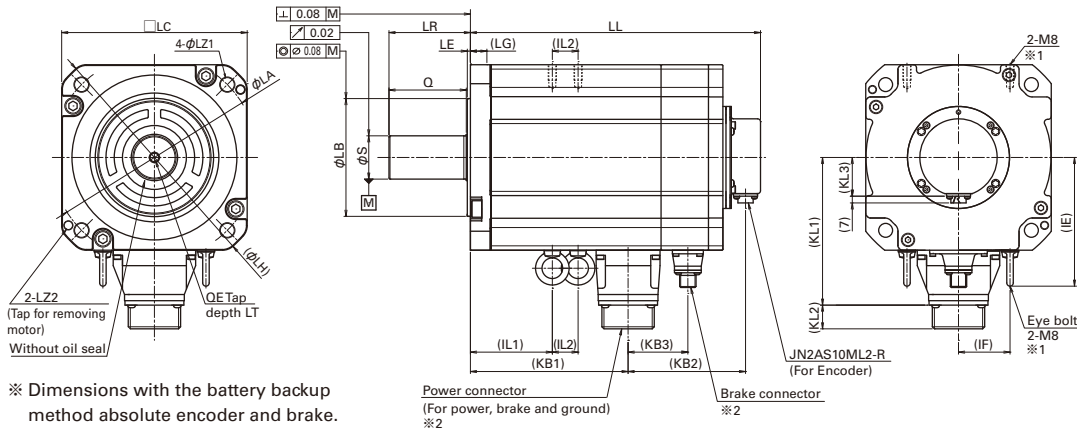

* Dimensions with the battery backup method absolute encoder and brake.

MODEL	Battery backup method absolute encoder, Absolute encoder for incremental system								Incremental encoder								LG	KL1	KL2	LA	LB
	Without brake				With brake				Without brake				With brake								
	LL	KB2	KB3	KL3	LL	KB2	KB3	KL3	LL	KB2	KB3	KL3	LL	KB2	KB3	KL3					
R2AA18350	155 (6.2)	48 (1.92)	-	-	204 (8.16)	97 (3.88)	-	-	172 (6.88)	59 (2.36)	-	-	221 (8.84)	108 (4.32)	-	-	16 (.64)	123 (4.92)	21 (.84)	200 (8)	0 0 0 (4.572 - .0014)
R2AA18450	172 (6.88)	-	-	38 (1.52)	221 (8.84)	-	-	38 (1.52)	189 (7.56)	-	-	65 (2.6)	238 (9.52)	-	-	65 (2.6)	19 (.76)	144 (5.76)	22 (.88)	-	-
R2AA18550	228 (9.12)	59 (2.36)	-	-	281 (11.24)	114 (4.56)	58 (2.32)	-	242 (9.68)	66 (2.64)	-	-	295 (11.8)	121 (4.84)	58 (2.32)	-	-	-	-	-	-
R2AA18750	273 (10.92)	-	-	-	336 (13.44)	124 (4.96)	68 (2.72)	-	287 (11.48)	-	-	-	350 (14)	131 (5.24)	68 (2.72)	-	-	-	-	-	-

MODEL	LE	LH	LC	LZ1	LZ2	LR	S	Q	KB1	QE	LT	IE	IF	IL1	IL2	Power connector model No.	Brake connector model No.
R2AA18350	-	-	-	-	-	65 (2.6)	0 35 -0.016 0 (1.4 - .00064)	60 (2.4)	92 (3.68)	M8	-	123 *1 (4.92)	50 *1 (2)	50 *1 (2)	20 *1 (.8)	JL04V-2E24-11PE-B-R	- *2
R2AA18450	3 (.12)	230 (9.2)	180 (7.2)	13.5 (.54)	M8	-	0 42 -0.016 0 (1.68 - .00064)	75 (3)	109 (4.36)	-	25 (1)	-	-	57 (2.28)	20 (.8)	-	-
R2AA18550	-	-	-	-	-	79 (3.16)	0 42 -0.016 0 (1.68 - .00064)	75 (3)	153 (6.12)	M10	-	123 (4.92)	50 (2)	63 (2.52)	41 (1.64)	JL04V-2E32-17PE-B-R	JL04V-2E10SL-3PE-B-R
R2AA18750	-	-	-	-	-	-	0 42 -0.016 0 (1.68 - .00064)	75 (3)	198 (7.92)	-	-	-	-	86 (3.44)	86 (3.44)	-	-

*1 The R2AA18350 motor without brake comes with no eye bolt.
*2 The brake line is shared with the power connector.

For the following encoders, please make inquiries:
· Resolver method batteryless absolute encoder [RA035C], High precision battery-less optical absolute encoder [HA062].

180mm sq. R2 Servo Motor Series 11kW

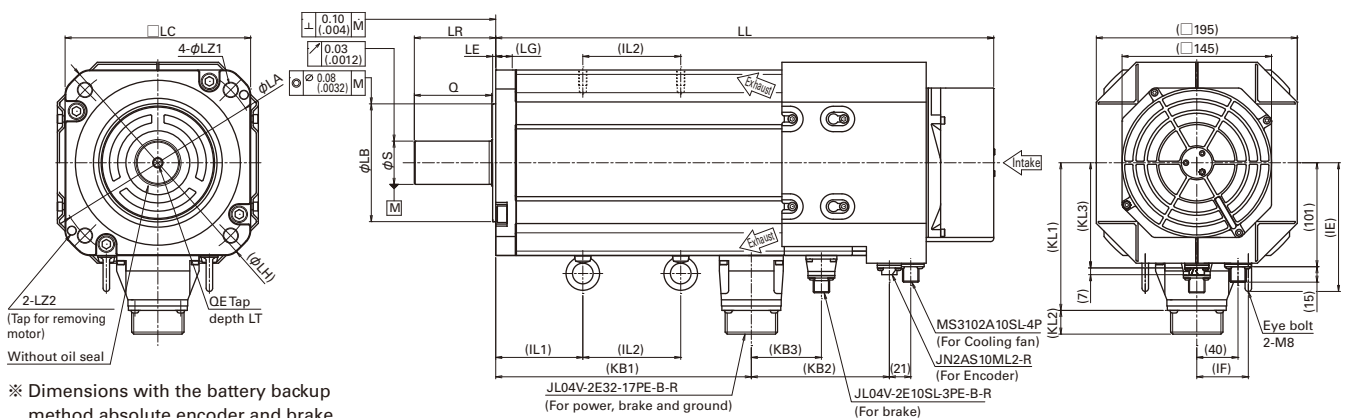

* Dimensions with the battery backup method absolute encoder and brake.

MODEL	Battery backup method absolute encoder, Absolute encoder for incremental system								Incremental encoder								LG	KL1	KL2	LA
	Without brake				With brake				Without brake				With brake							
	LL	KB2	KB3	KL3	LL	KB2	KB3	KL3	LL	KB2	KB3	KL3	LL	KB2	KB3	KL3				
R2AA1811K	385 (15.4)	59 (2.36)	-	102 (4.08)	518 (19.12)	149 (6.16)	123 (3.32)	102 (4.08)	385 (15.4)	-	66 (2.64)	102 (4.08)	518 (19.12)	201 (6.12)	123 (3.32)	102 (4.08)	19 (.76)	144 (5.76)	22 (.88)	200 (8)

MODEL	LB	LE	LH	LC	LZ1	LZ2	LR	S	Q	KB1	QE	LT	IE	IF	IL1	IL2
R2AA1811K	0 114.3 -0.035 0 (4.572 - .0014)	3 (.12)	230 (9.2)	180 (7.2)	13.5 (.54)	M8	79 (3.16)	42 -0.016 0 (1.68 - .00064)	75 (3)	223 (3.92)	M10	25 (1)	123 (4.92)	50 (2)	63 (2.52)	111 (4.44)

For the following encoders, please make inquiries:
· Resolver method batteryless absolute encoder [RA035C], High precision battery-less optical absolute encoder [HA062].

Features and Functions
Model No. List - Model Number Nomenclature
System Configuration
Standard Specifications
Encoder Wiring Diagram
External Wiring Diagram
Dimensions
Setup Software
Option

180mm sq.

R1 Servo Motor Series 5.5kW to 15kW

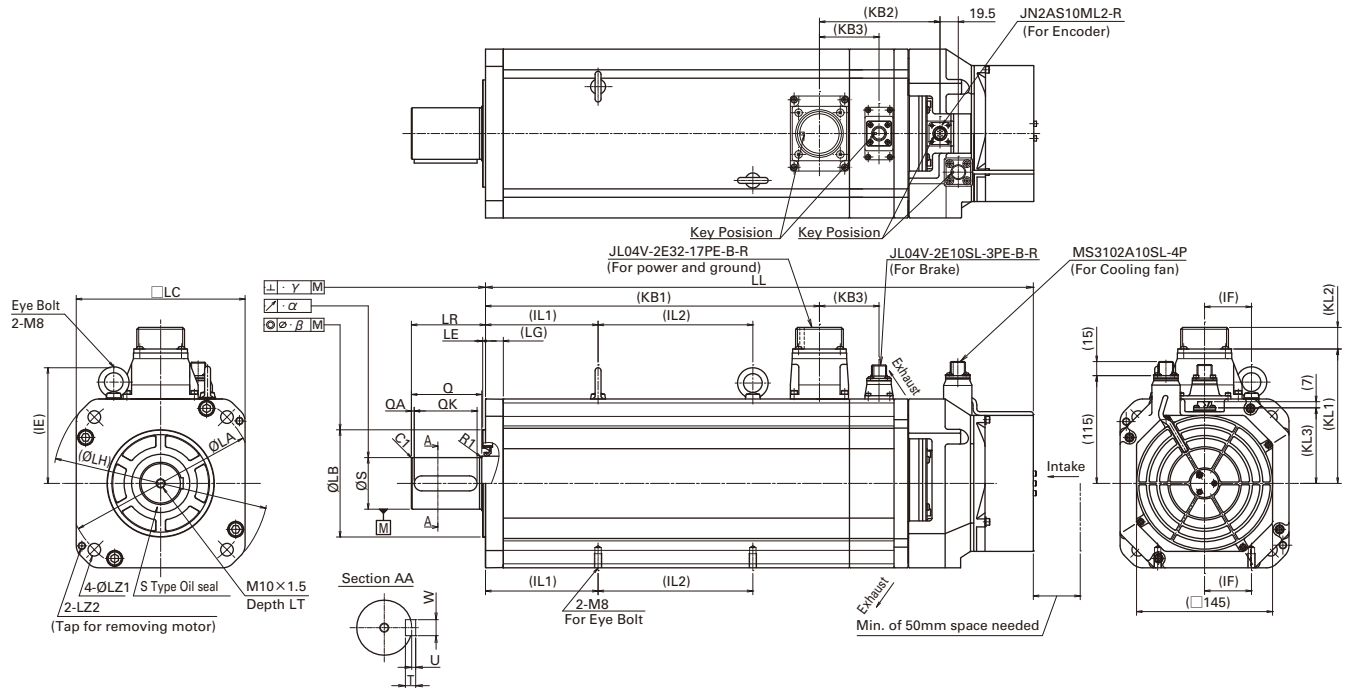

Battery backup method absolute encoder,
Absolute encoder for incremental system

MODEL	Without brake			With brake			LG	KL1	KL2	LA	KB	LE	LH	LC	LZ1	LZ2	LR
	LL	KB2	KB3	KL3	LL	KB2											
R1AA18550	352	80	-	81	407	118	53	19	144	22	200	3	230	180	13.5	M8	79
R1AA18750	387				445	128	63										
R1AA1811K	457				531	144	79										
R1AA1815K	535				625	168	103										

MODEL	S	Q	QA	QK	W	T	U	KB1	α	β	γ	QE	LT	IE	IF	IL1	IL2
R1AA18550	42	75	3	67	12	8	3	172	0.02	0.08	0.08	M10	25	124	50	53	65
R1AA18750								207								68	85
R1AA1811K								277								68	163
R1AA1815K								356								92	210

Electric wire diameters

Voltage	Flange Size (mm)	MODEL	Armature Stall Current (Is)	Power receptacle		Maximum wire size of connector				Receptacle permissible current	Applicable amplifier model No.	Recommended motor power wire size ※		Wire size of main power supply			
				Shell Size	Contact Size	MS Type		JL04V Type				mm ²	AWG No.	mm ²	AWG No.	mm ²	AWG No.
						Arms	Arms	mm ²	AWG No.								
200V	180	R1AA18550H	47	32-17P	#4	22	#4	22	#4	70	RS2A30	14	#6	14	#6		
		R1AA18750H	53														
		R1AA1811KR	54														
		R1AA1815KB	58														

※Use of heat-resistant vinyl wire (HIV) is recommended.

Features and Functions
 Model No. List - Model Number Nomenclature
 System Configuration
 Standard Specifications
 Encoder Wiring Diagram
 External Wiring Diagram
 Dimensions
 Setup Software
 Option

100mm sq. to 220mm sq.

Q1 Servo Motor Series Q2 Servo Motor Series

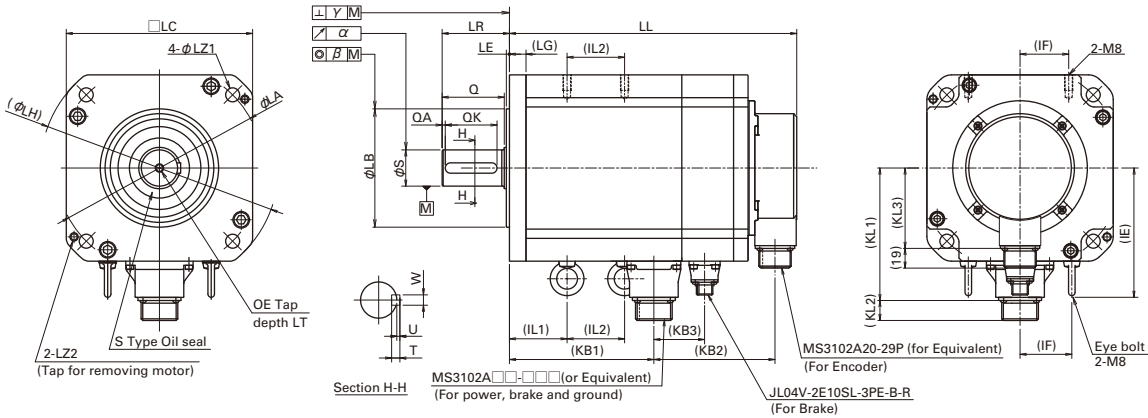

Q1 Servo Motor Series

MODEL	Incremental encoder		LL	KB2	KB3	LG	KL1	KL2	KL3	LA	LB	LE	LH	LC	LZ1	LZ2	LR	S	Q	QA
	Without brake	With brake																		
Q1AA10100	184 (7.36)	219 (8.76)																0	40	3
Q1AA10150	209 (8.36)	244 (9.76)	80 (3.2)	116 (4.64)	51 (2.04)	10 (.4)	78 (3.12)	19 (.76)	63 (2.52)	115 (4.6)	0.95-0.035 (.038-.0014)	3 (.12)	130 (5.2)	100 (4)	9 (.36)	-	45 (1.8)	22-0.013 0 (.88-.00052)	40 (1.6)	3 (.12)
Q1AA10200	234 (9.36)	269 (10.76)																0	40	3
Q1AA10250	259 (10.36)	294 (11.76)																0	40	3
Q1AA12100	168 (6.72)	204 (8.16)																0	40	3
Q1AA12200	205 (8.2)	241 (9.64)	72 (2.88)	108 (4.32)	45 (1.8)	12 (.48)	93 (3.72)	21 (.84)	67 (2.68)	135 (5.4)	110-0.035 0 (4.4-.0014)	3 (.12)	162 (6.48)	120 (4.8)	9 (.36)	-	45 (1.8)	22-0.013 0 (.88-.00052)	40 (1.6)	3 (.12)
Q1AA12300	242 (9.68)	278 (11.12)																0	50	3
Q1AA13300	205 (3.2)	254 (10.16)																0	50	3
Q1AA13400	232 (9.28)	281 (11.24)	67 (2.68)	117 (4.68)	-	12 (.48)	98 (3.92)	.84	80 (3.2)	145 (5.8)	110-0.035 0 (4.4-.0014)	4 (.16)	165 (6.6)	130 (5.2)	9 (.36)	M6	55 (2.2)	28-0.013 0 (1.12-.00052)	50 (2)	3 (.12)
Q1AA13500	269 (10.76)	318 (12.72)																0	50	3

MODEL	QK	W	T	U	KB1	α	β	γ	QE	LT	IE	IF	IL1	IL2	Power connector model No. ^{*1}	Brake connector model No. ^{*2}
Q1AA10100					84 (3.36)										MS3102A20-15P	JL04V-2E10SL-3PE-B-R
Q1AA10150	32 (1.28)	0 6-0.030 (.24-.0012)	6 (.24)	2.5 (.1)	109 (4.36)	0.02 (.0008)	0.08 (.0032)	0.08 (.0032)	M6	20 (.8)	-	-	-	-		
Q1AA10200					134 (5.36)											
Q1AA10250					159 (6.36)											
Q1AA12100	32 (1.28)	0 6-0.030 (.24-.0012)	6 (.24)	2.5 (.1)	76 (3.04)										MS3102A24-11P	JL04V-2E10SL-3PE-B-R
Q1AA12200					113 (4.52)	0.02 (.0008)	0.08 (.0032)	0.08 (.0032)	M6	20 (.8)	-	-	-	-		
Q1AA12300	42 (1.68)	0 8-0.036 (.32-.0012)	7 (.28)	3 (.12)	150 (6)				M8	25 (1)						
Q1AA13300					117 (4.68)										MS3102A24-11P ^{*3}	
Q1AA13400	42 (1.68)	0 8-0.036 (.32-.0012)	7 (.28)	3 (.12)	144 (5.76)	0.02 (.0008)	0.08 (.0032)	0.08 (.0032)	M8	25 (1)	-	-	-	-		
Q1AA13500					181 (7.24)											

*1 Waterproof specification IP67 requires that the connector to be attached ; for IP67 compliance, use a waterproof connector for the mating plug.

*2 All brake connectors are JL04V-2E10SL-3PE-B-R for CE compliant DC24V brakes.

*3 The brake line is shared with the power connector.

*Please inquire for the dimensions with the absolute encoder.

Q2 Servo Motor Series

MODEL	Incremental encoder																S	Q	QA		
	Without brake			With brake			LG	KL1	KL2	KL3	LA	LB	LE	LH	LC	LZ1				LZ2	LR
	LL	KB2	KB3	LL	KB2	KB3															
Q2AA18200	171 (6.84)	67 (2.68)	221 (8.84)	117 (4.68)	-	16 (.64)	123 (4.92)	21 (.84)	80 (3.2)	200 (8)	114.3-0.035 0 (4.572-.0014)	3 (.12)	230 (9.2)	180 (7.2)	13.5 (.54)	M8	65 (2.6)	35-0.016 0 (1.4-.0064)	60 (2.4)	3 (.12)	
Q2AA22550	252 (10.08)	83 (3.32)	309 (12.36)	141 (5.64)	82 (3.28)	19 (.76)	141 (5.64)	21 (.84)	80 (3.2)	235 (9.4)	200-0.046 0 (8-.00184)	4 (.16)	270 (10.8)	220 (8.8)	13.5 (.54)	M10	79 (3.16)	55-0.019 0 (2.2-.00076)	75 (3)	3 (.12)	
Q2AA22700	310 (12.4)	83 (3.32)	368 (14.72)	141 (5.64)	82 (3.28)	19 (.76)	141 (5.64)	21 (.84)	80 (3.2)	235 (9.4)	200-0.046 0 (8-.00184)	4 (.16)	270 (10.8)	220 (8.8)	13.5 (.54)	M10	79 (3.16)	55-0.019 0 (2.2-.00076)	75 (3)	3 (.12)	
Q2AA2211K	335 (13.4)	73 (2.92)	393 (15.72)	61 (2.44)	131 (5.24)	19 (.76)	162 (6.48)	22 (.88)	80 (3.2)	235 (9.4)	200-0.046 0 (8-.00184)	4 (.16)	270 (10.8)	220 (8.8)	13.5 (.54)	M10	79 (3.16)	0 (2.2-.00076)	75 (3)	3 (.12)	
Q2AA2215K	394 (15.76)	73 (2.92)	452 (18.08)	61 (2.44)	131 (5.24)	19 (.76)	162 (6.48)	22 (.88)	80 (3.2)	235 (9.4)	200-0.046 0 (8-.00184)	4 (.16)	270 (10.8)	220 (8.8)	13.5 (.54)	M10	79 (3.16)	0 (2.2-.00076)	75 (3)	3 (.12)	

MODEL	QK	W	T	U	KB1	α	β	γ	QE	LT	IE	IF	IL1	IL2	Power connector model No. ^{※1}	Brake connector model No. ^{※2}
Q2AA18200	50 (2)	10-0.036 0 (.4-.00143)	8 (.32)	3 (.12)	83 (3.32)	0.02 (.0008)	0.08 (.0032)	0.08 (.0032)	M8	25 (1)	-	-	-	-	MS3102A24-11P ^{※3}	
Q2AA22550	67 (2.68)	16-0.043 0 (.64-.00172)	10 (.4)	4 (.16)	149 (5.96) 207 (8.28)	0.03 (.0012)	0.08 (.0032)	0.08 (.004)	M10	25 (1)	142 (5.68)	60 (2.4)	55 (2.2)	50 (2) 110 (4.4)	MS3102A24-11P	JL04V-2E10SL-3PE-B-R
Q2AA22700	67 (2.68)	16-0.043 0 (.64-.00172)	10 (.4)	4 (.16)	241 (9.64) 300 (12)	0.03 (.0012)	0.08 (.0032)	0.10 (.004)	M10	25 (1)	142 (5.68)	60 (2.4)	69 (2.76)	120 (4.8) 180 (7.2)	MS3102A32-17P	
Q2AA2211K	67 (2.68)	16-0.043 0 (.64-.00172)	10 (.4)	4 (.16)	241 (9.64) 300 (12)	0.03 (.0012)	0.08 (.0032)	0.10 (.004)	M10	25 (1)	142 (5.68)	60 (2.4)	69 (2.76)	120 (4.8) 180 (7.2)	MS3102A32-17P	
Q2AA2215K	67 (2.68)	16-0.043 0 (.64-.00172)	10 (.4)	4 (.16)	241 (9.64) 300 (12)	0.03 (.0012)	0.08 (.0032)	0.10 (.004)	M10	25 (1)	142 (5.68)	60 (2.4)	69 (2.76)	120 (4.8) 180 (7.2)	MS3102A32-17P	

※1 Waterproof specification IP67 requires that the connector to be attached ; for IP67 compliance, use a waterproof connector for the mating plug.

※2 All brake connectors are JL04V-2E10SL-3PE-B-R for CE compliant DC24V brakes.

※3 The brake line is shared with the power connector.

※Please inquire for the dimensions with the absolute encoder.

Electric wire diameters

Voltage	Flange Size (mm)	MODEL	Armature Stall Current (Is)	Power receptacle		Maximum wire size of connector				Receptacle permissible current	Applicable amplifier model No.	Recommended motor power wire size ※ (U, V, W, Ground)		Wire size of main power supply (R, S, T, Ground)			
				Shell Size	Contact Size	MS Type		JL04V Type				mm ²	AWG No.	mm ²	AWG No.	mm ²	AWG No.
						mm ²	AWG No.	mm ²	AWG No.								
200V	100	Q1AA10100D	7.8	20-15P	#12	3.5	#12	3.5	#12	20	RS2A05	3.5	#12	3.5	#12		
		Q1AA10150D	8.2														
		Q1AA10200D	17.2														
		Q1AA10250D	17.2														
	120	Q1AA12100D	7.5	24-11P	#8	8	#8	5.5	#10	40	RS2A05	3.5	#12	3.5	#12		
		Q1AA12200D	16.2														
		Q1AA12300D	17.3														
		Q1AA13300D	17.6														
	130	Q1AA13400D	26.4	24-11P	#8	8	#8	5.5	#10	40	RS2A10	5.5	#10	5.5	#10		
		Q1AA13500D	27.5														
		Q2AA18200H	18														
	220	Q2AA22550B	35.1	24-11P	#8	8	#8	5.5	#10	40	RS2A15	5.5	#10	8	#8		
		Q2AA22700S	34														
		Q2AA2211KV	66	32-17P	#4	22	#4	22	#4	70	RS2A30	14	#6	14	#6		
Q2AA2215KV		66															

※Use of heat-resistant vinyl wire (HIV) is recommended.

Features and Functions

Model No. List - Model Number Nomenclature

System Configuration

Standard Specifications

Encoder Wiring Diagram

External Wiring Diagram

Dimensions

Setup Software

Option

Servo Amplifier Dimensions [Unit : mm (inch)]

15A

Mass : 0.75kg

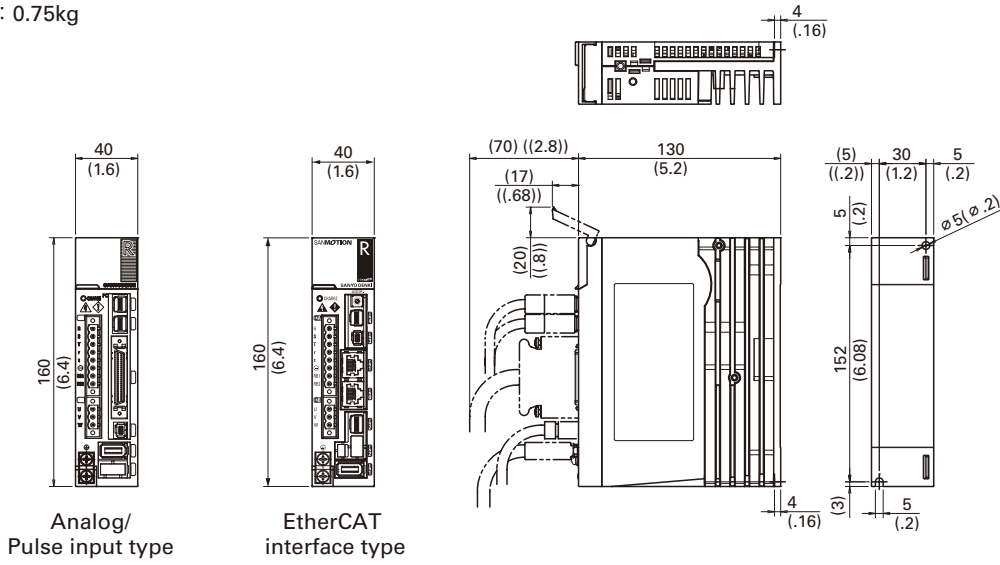

Analog/
Pulse input type

EtherCAT
interface type

30A

Mass : 0.9kg

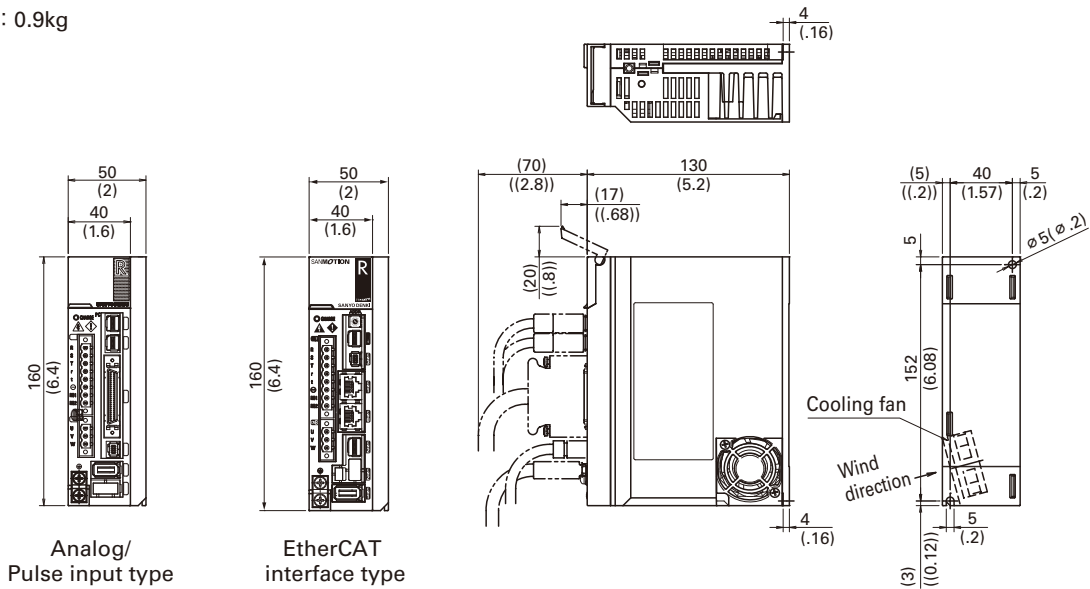

Analog/
Pulse input type

EtherCAT
interface type

50A

Mass : 1.65kg

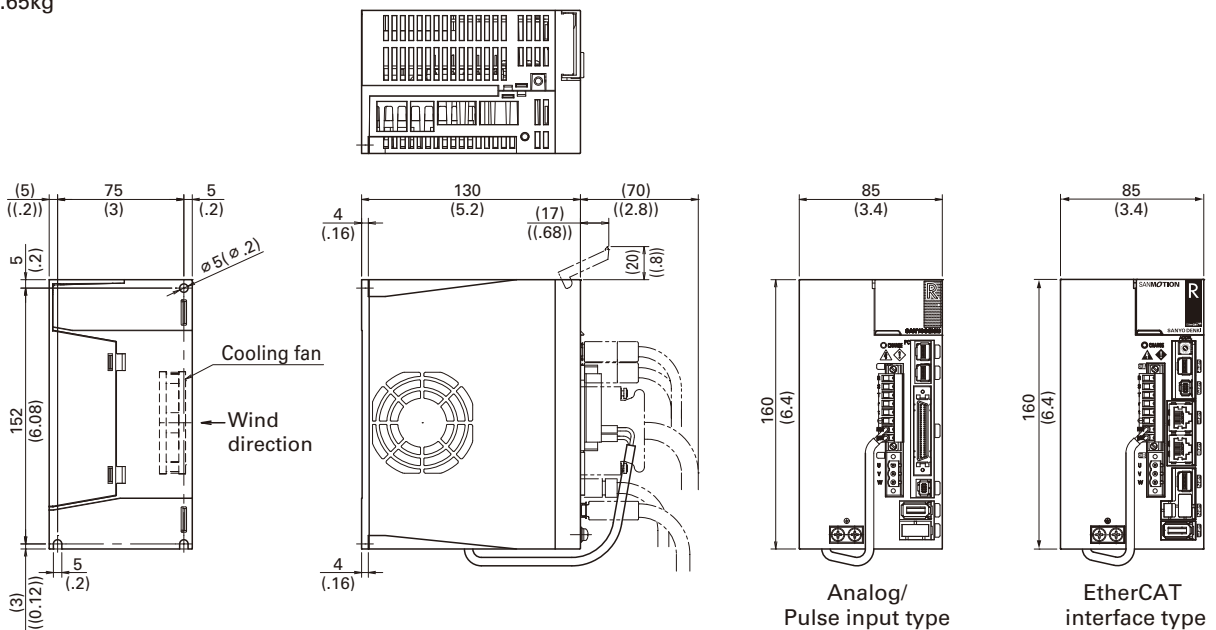

Analog/
Pulse input type

EtherCAT
interface type

100A

Mass : 5.0kg

Analog / Pulse input type

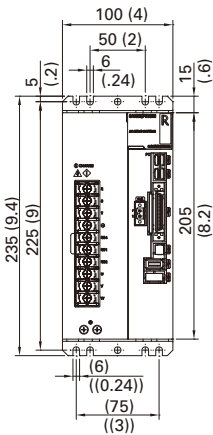

EtherCAT interface type

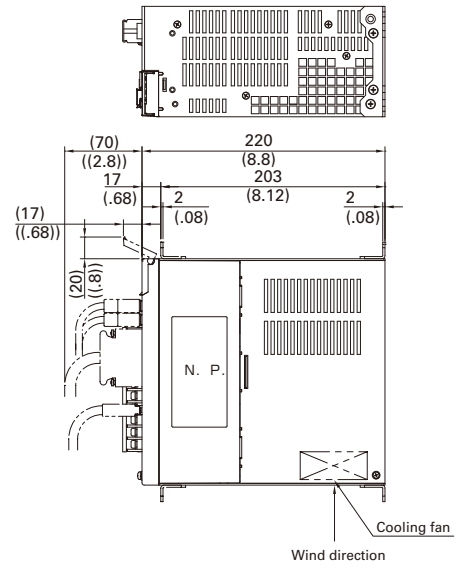
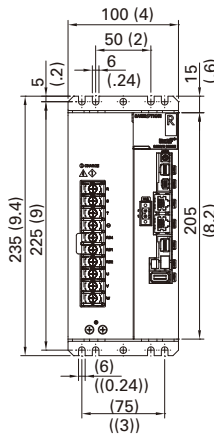

150A

Mass : 5.3kg

Analog / Pulse input type

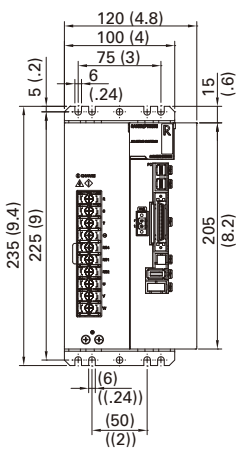

EtherCAT interface type

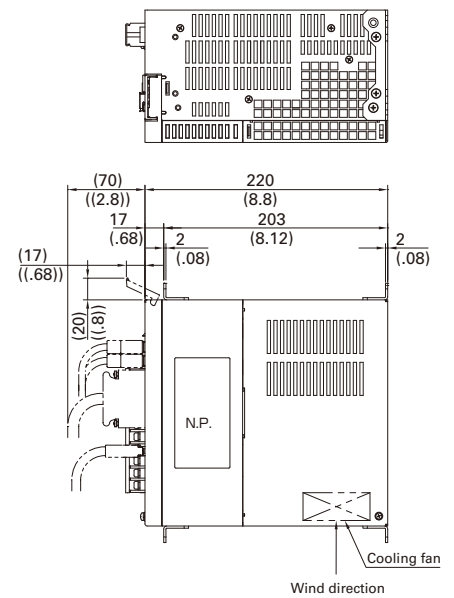
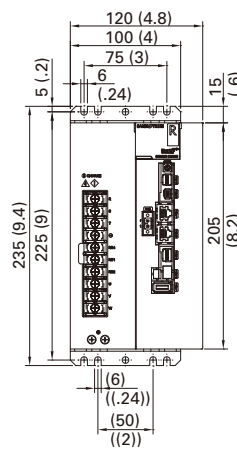

300A

Mass : 9.6kg

Analog / Pulse input type

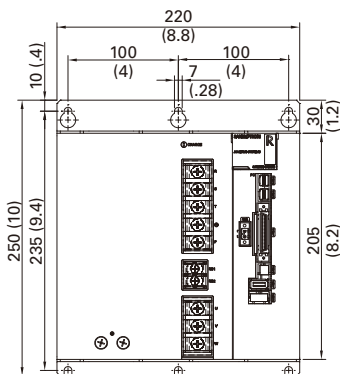

EtherCAT interface type

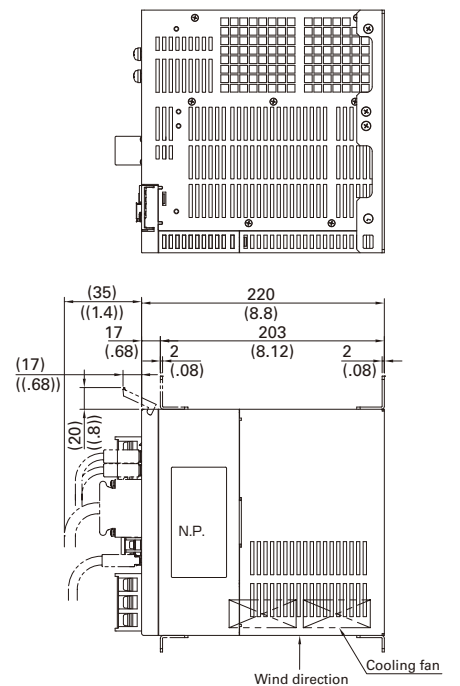
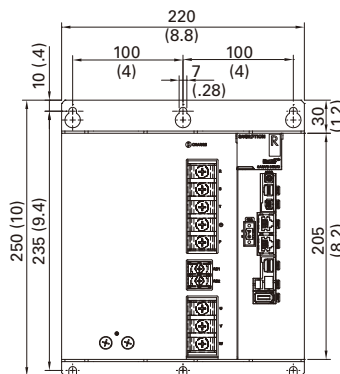

Features and Functions

Model No. List - Model Number Nomenclature

System Configuration

Standard Specifications

Encoder Wiring Diagram

External Wiring Diagram

Dimensions

Setup Software

Option

Setup Software

This software allows you to set servo system parameters from a PC. It also allows you easily to start up or test run the servo system. The software can be downloaded from Production Information on our website. URL : <http://www.sanyodenki.co.jp>



Start-up Screen

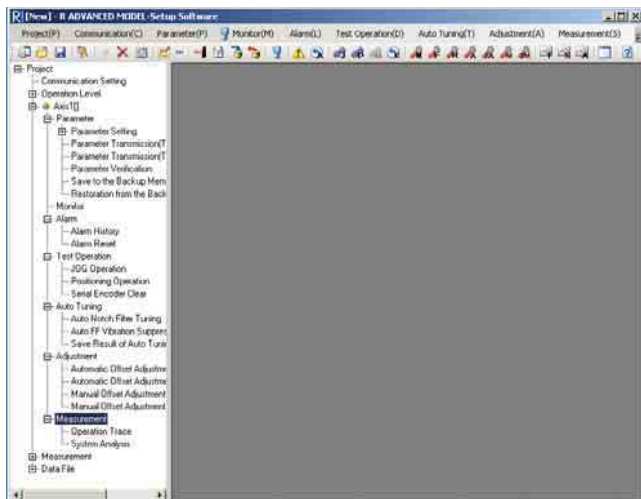

Main Screen

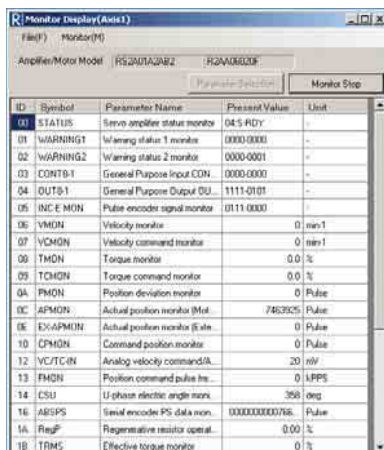

Monitor Display

Observe Operation and Input/Output signal status

Setup Software Title :

R-ADVANCED MODEL-Setup Software

Main Functions

Servo amplifier parameter setting

Servo amplifier status display

Alarm display and reset

Test run execution

Auto-tuning of vibration control frequency, etc.

Analog command offset adjustment

*Use the optional PC connection cable (model No.: AL-00689703-01) to connect the servo amplifier and the RS-232C port on the PC.

Supported OS

Windows 98/SE/Me/2000/XP/Vista/7

*See our website for details of supported versions.

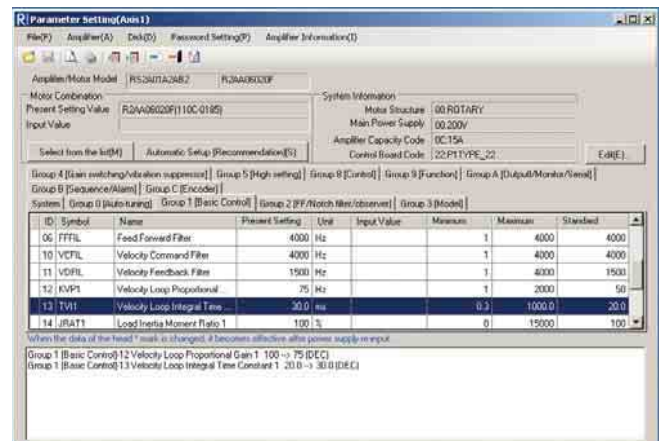

Configuration parameters

Enables parameter loading, saving, etc., via PC connection

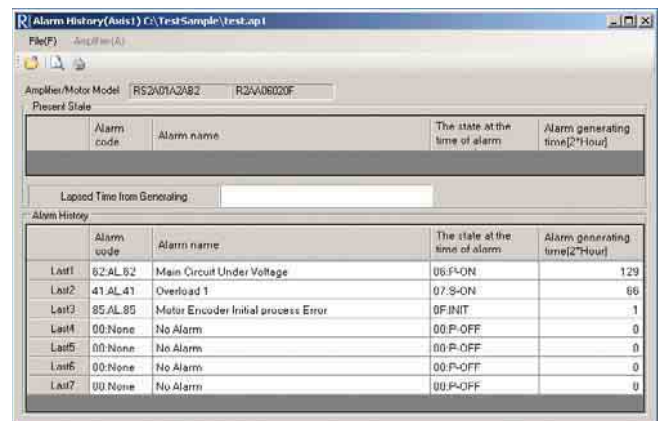

Alarm Record Display

Current and past alarm occurrence can be checked.

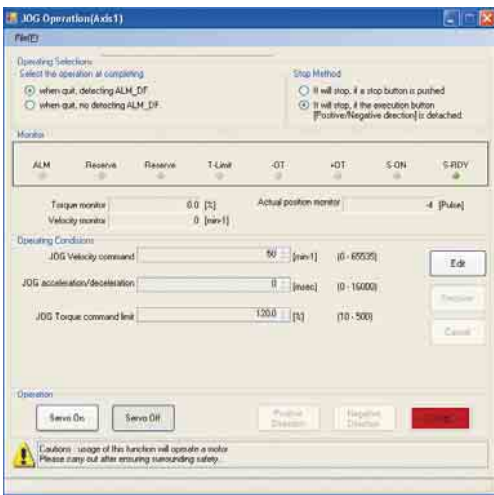

JOG Operation

Simplifies motor operation and the issuing of speed commands from a PC

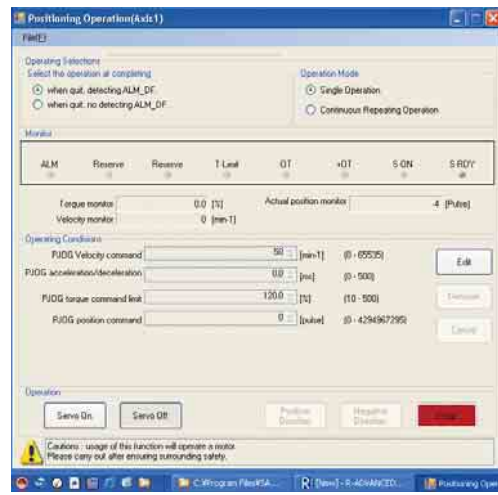

Positioning Control Operation

The position can be moved by setting the feed velocity and the pulse number of the servo motor.

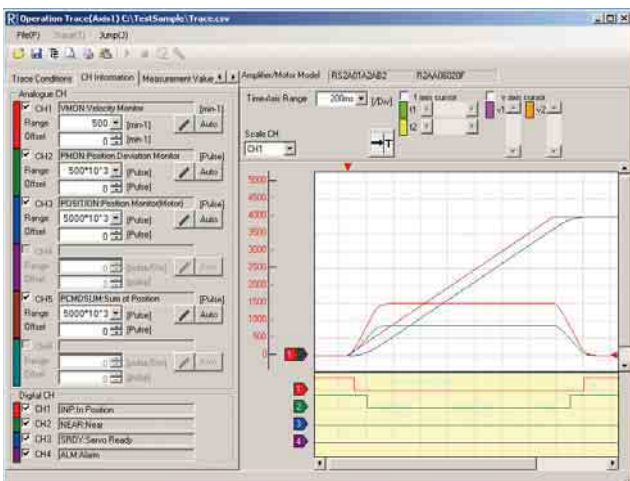

Operation Trace

Graphically displays servo motor speed, current, and internal status

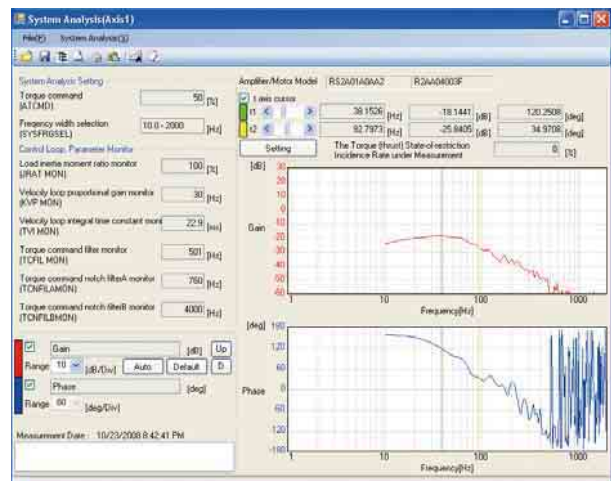

System Analysis

Analyzes servo system frequency characteristics

Connectors of Servo Amplifier Analog/Pulse input type

15A, 30A, 50A

Single Connectors

Connector No.	Item	Model No.	Manufacturer model No.	Manufacturer
CN1	To connect host device	AL-00385594	10150-3000PE 10350-52A0-008	Sumitomo 3M Limited
EN1, EN2	To connect encoder	AL-00632607	36210-0100PL 36310-3200-008	
CNA	For input power supply, regenerative resistor connection	AL-00686902-01	MSTBT2.5/8-STF-5.08LUB	Phoenix Contact.K.K
CNB	To connect servo motor	AL-Y0004079-01	MSTBT2.5/3-STF-5.08	
CN4 ^{※1}	To connect safety device (For short-circuiting)	AL-00718251-01	2040978-1	Tyco Electronics Japan G.K.
CN4	To connect safety device (For wiring)	AL-00718252-01	2013595-3	

※1 When wiring for CN4 is not performed, make sure to insert safety device connector (for short-circuiting) to CN4 on servo amplifier.

Connector sets (No safe-torque-off function)

Connector No.	Item	Model No.	Applicable servo amplifier model No.	Remarks
CN1,EN1,CNA,CNB	Standard	AL-00723282	RS2□□□A0□L0/RS2□□□A8□L0	Without regenerative resistance
CN1,EN1,CNB		AL-00723284	RS2□□□A0□A0/RS2□□□A8□A0	With regenerative resistance
CN1,EN1,EN2,CNA,CNB	For fully closed control system	AL-00723286	RS2□□□A2□L0/RS2□□□AA□L0	Without regenerative resistance
CN1,EN1,EN2,CNB		AL-00723288	RS2□□□A2□A0/RS2□□□AA□A0	With regenerative resistance
CN1,EN1	Low voltage set	AL-00723290	RS2□□□A0□□0/RS2□□□A8□□0	—
CNA,CNB	High voltage set	AL-00696037	RS2□□□A□□L0	Without regenerative resistance

Connector sets (With safe-torque-off function)

Connector No.	Item	Model No.	Applicable servo amplifier model No.	Remarks
CN1,EN1,CNA,CNB,CN4	Standard	AL-00723155	RS2□□□A0□L2(4)/RS2□□□A8□L2(4)	Without regenerative resistance
CN1,EN1,CNB,CN4		AL-00723156	RS2□□□A0□A2(4)/RS2□□□A8□A2(4)	With regenerative resistance
CN1,EN1,EN2,CNA,CNB,CN4	For fully closed control system	AL-00723157	RS2□□□A2□L2(4)/RS2□□□AA□L2(4)	Without regenerative resistance
CN1,EN1,EN2,CNB,CN4		AL-00723158	RS2□□□A2□A2(4)/RS2□□□AA□A2(4)	With regenerative resistance
CN1,EN1,CN4	Low voltage set	AL-00723159	RS2□□□A0□□2(4)/RS2□□□A8□□2(4)	—

※ CN4 of the connector set is for safety device connection (wiring) with model number AL-00718252-01.

100A, 150A, 300A

Single Connectors

Connector No.	Item	Model No.	Manufacturer model No.	Manufacturer
CN1	To connect host device	AL-00385594	10150-3000PE 10350-52A0-008	Sumitomo 3M Limited
EN1, EN2	To connect encoder	AL-00632607	36210-0100PL 36310-3200-008	
CNA	To input control power	AL-Y0005159-01	MSTBT2.5/2-STF-5.08	Phoenix Contact.K.K
CN4 ^{※1}	To connect safety device (For short-circuiting)	AL-00718251-01	2040978-1	Tyco Electronics Japan G.K.
CN4	To connect safety device (For wiring)	AL-00718252-01	2013595-3	

※1 When wiring for CN4 is not performed, make sure to insert safety device connector (for short-circuiting) to CN4 on servo amplifier.

Connector sets (No safe-torque-off function)

Connector No.	Item	Model No.	Applicable servo amplifier model No.
CN1,EN1,CNA	Standard	AL-00751448	RS2□□□A0A□0/RS2□□□A8A□0
CN1,EN1,EN2,CNA	For fully closed control system	AL-00751450	RS2□□□A2A□0/RS2□□□AAA□0
CN1,EN1	Low voltage set	AL-00723290	RS2□□□A0A□0/RS2□□□A8A□0

Connector sets (With safe-torque-off function)

Connector No.	Item	Model No.	Applicable servo amplifier model No.
CN1,EN1,CNA,CN4	Standard	AL-00751452	RS2□□□A0A□2(4)/RS2□□□A8A□2(4)
CN1,EN1,EN2,CNA,CN4	For fully closed control system	AL-00751454	RS2□□□A2A□2(4)/RS2□□□AAA□2(4)
CN1,EN1,CN4	Low voltage set	AL-00723159	RS2□□□A0A□2(4)/RS2□□□A8A□2(4)

Connector for Servo Amplifier EtherCAT interface type 15A, 30A, 50A

Single Connectors

Connector No.	Item	Model No.	Manufacturer model No.	Manufacturer
CN0,CN1	Ethernet For host device connection	Not provided by our company. Please use shielded type modular plug (RJ-45) corresponding to the CAT5e standard.		
EN1,EN2	For encoder connection	AL-00632607	36210-0100PL 36310-3200-008	Sumitomo 3M Limited
CNA	For input power supply, regenerative resistor connection	AL-00686902-01	MSTBT2.5/8-STF-5.08LUB	Phoenix Contact.K.K
CNB	For servo motor connection	AL-Y0004079-01	MSTBT2.5/3-STF-5.08	Phoenix Contact.K.K
CN2	For safety device connection	AL-Y0004290-02	MUF-PK10K-X	J.S.T Mfg Co.,Ltd.
CN3	For general I/O	AL-00718252-01	2013595-3	Tyco Electronics Japan G.K.

Connector sets

Connector No.	Item	Model No.	Applicable servo amplifier model No.	Remarks
CNA,CNB,EN1,CN2,CN3	Standard	AL-00734194	RS2□□□A0KL□/RS2□□□A8KL□	Without regenerative resistance
CNB,EN1,CN2,CN3		AL-00734196	RS2□□□A0KA□/RS2□□□A8KA□	With regenerative resistance
CNA,CNB,EN1,EN2,CN2,CN3	For fully closed control system	AL-00734195	RS2□□□A2KL□/RS2□□□AAKL□	Without regenerative resistance
CNB,EN1,EN2,CN2,CN3		AL-00734197	RS2□□□A2KA□/RS2□□□AAKA□	With regenerative resistance

100A, 150A, 300A

Single Connectors

Connector No.	Item	Model No.	Manufacturer model No.	Manufacturer
CN0,CN1	Ethernet For host device connection	Not provided by our company. Please use shielded type modular plug (RJ-45) corresponding to the CAT5e standard.		
EN1, EN2	For encoder connection	AL-00632607	36210-0100PL 36310-3200-008	Sumitomo 3M Limited
CNA	To input control power	AL-Y0005159-01	MSTBT2.5/2-STF-5.08	Phoenix Contact.K.K
CN2	For safety device connection	AL-Y0004290-02	MUF-PK10K-X	J.S.T Mfg Co.,Ltd.
CN3	For general I/O	AL-00718252-01	2013595-3	Tyco Electronics Japan G.K.

Connector sets

Connector No.	Item	Model No.	Applicable servo amplifier model No.
CNA,EN1,CN2,CN3	Standard	AL-00756240	RS2□□□A0K□□/RS2□□□A8K□□
CNA,EN1,EN2,CN2,CN3	For fully closed control system	AL-00756242	RS2□□□A2K□□/RS2□□□AAK□□
EN1,CN2,CN3	Low voltage set	AL-00756244	RS2□□□A0K□□/RS2□□□A8K□□
EN1,EN2,CN2,CN3	For fully closed control system Low voltage set	AL-00756246	RS2□□□A2K□□/RS2□□□AAK□□

Features and Functions

Model No. List - Model Number Nomenclature

System Configuration

Standard Specifications

Encoder Wiring Diagram

External Wiring Diagram

Dimensions

Setup Software

Option

Servo Motor Encoder Connectors Model No. R2 Servo Motor

Motor type	Encoder receptacle	Applicable cable diameter (bushing color phase)	Combination plug for encoder (with rubber bushing)		Pin Layout Symbol
			Straight	Angle	
All R2 Servo Motor Models	JN2AS10ML2-R	φ 5.7 to 7.3 (Black)	JN2DS10SL1-R	JN2FS10SL1-R	See the encoder wiring diagram on Page 41.
		φ 6.5 to 8.0 (Gray)	JN2DS10SL2-R	JN2FS10SL2-R	
		φ 3.5 to 5.0 (Black)	JN2DS10SL3-R	JN2FS10SL3-R	

Please select the correct plug and contacts for the size of cable to be used. The manufacturer's model number and the model number for parts procured from SANYO DENKI are the same number.

Applicable contact for encoder plug ※1, 2

Contact size	Category	Applicable contact	
		Socket contact model No.	Applicable wire size
#22	Manual crimp tool type ※ 3, 4	JN1-22-20S-R-PKG100	AWG #20
		JN1-22-22S-PKG100	AWG #21 to #25
		JN1-22-26S-PKG100	AWG #26 to #28
	Solder type	JN1-22-22F-PKG100	AWG #20

- ※ 1 : Please select the correct plug and contacts for the size of cable to be used. The manufacturer's model number and the model number for parts procured from SANYO DENKI are the same number.
 ※ 2 : When removing a contact that has already been inserted, please use a removal tool. Please purchase the removal tool from the connector manufacturer (Japan Aviation Electronics Industry Limited).
 ※ 3 : For the manual crimp tool part number, see the instruction manuals from the connector manufacturer (Japan Aviation Electronics Industry Limited).
 ※ 4 : Please purchase the semi-automatic crimp tool from the connector manufacturer (Japan Aviation Electronics Industry Limited).
 ※ 5 : For the connector and contact instructions, precautions, etc., please see the catalogs and instruction manuals from the connector manufacturer (Japan Aviation Electronics Industry Limited).

Q1, Q2 Servo Motor

Motor type	Encoder receptacle	Standard Encoder Plug (Cable Clamp) [Plug + Clamp]		TUV-Conforming Plug (Cable Clamp) for Encoder Waterproof Specification [Plug + Clamp]		Pin Layout Symbol
		Straight	Angle	Straight	Angle	
Q1, Q2 Servo Motor Models	MS3102A20-29P	MS3106B20-29S (MS3057-12A) [MS06B20-29S-12]	MS3108B20-29S (MS3057-12A) [MS08B20-29S-12]	JA06A20-29S-J1-EB (JL04-2022CK(14)-R)	JA08A20-29S-J1-EB (JL04-2022CK(14)-R)	See the encoder wiring diagram on Page 41.

[] indicates the SANYO DENKI part numbers (Plug & Cable Clamp)

Cooling Fan Connectors

Motor type	Cooling fan receptacle	Standard plug (Cable Clamp) for Cooling Fan [Plug + Clamp]		Waterproof plug (Cable Clamp) for Cooling Fan [Plug + Clamp]		Pin Layout Symbol
		Straight	Angle	Straight	Angle	
R1, R2 Servo Motor	MS3102A10SL-4P	MS3106B10SL-4S (MS3057-4A) [MS06B10SL-4S-4]	MS3108B10SL-4S (MS3057-4A) [MS08B10SL-4S-4]	JA06A10SL-4S-J1 (conduit)		Please prepare the conduit by customer. A B

Please see the catalogs and instruction manuals of the connector manufacturer's (Japan Aviation Electronics Industry Limited) for details, including the instructions for the connector and the precautions.
 [] indicates the SANYO DENKI part numbers (Plug & Cable Clamp)

Motor Connectors Model No. ※1, 4

Voltage	Flange Size	Motor Model No.	Motor power receptacle	Brake receptacle Standard specifications, TUV specifications: DC90V (※ 4 1TUV: DC24V only)	Plug for power line (Cable Clamp) [Plug + Clamp]		TUV-Standard Plug Waterproof Specification (Cable Clamp) [Plug + Clamp]	
					Straight	Angle	Straight	Angle
					200V Type	130mm	R2AA13050 R2AA13120 R2AA13180 R2AA13200	JL04V-2E24-11PE-B-R
180mm	R2AA18350 R2AA18450 R2AA18550 R2AA18750 R2AA1811K	JL04V-2E24-11PE-B-R	※ 3	MS3106B24-11S (MS3057-16A) [MS06B24-11S-16]	MS3108B24-11S (MS3057-16A) [MS08B24-11S-16]	JL04V-6A24-11SE-EB-R (JL04-2428CK-R) [332706X10]	JL04V-8A24-11SE-EB-R (JL04-2428CK-R) [332707X10]	
220mm	R2AA22350 R2AA22500	JL04V-2E24-11PE-B-R	※ 3	MS3106B24-11S (MS3057-16A) [MS06B24-11S-16]	MS3108B24-11S (MS3057-16A) [MS08B24-11S-16]	JL04V-6A24-11SE-EB-R (JL04-2428CK-R) [332706X10]	JL04V-8A24-11SE-EB-R (JL04-2428CK-R) [332707X10]	
180mm	R1AA18550H R1AA18750H R1AA1811KR R1AA1815KB	JL04V-2E32-17PE-B-R	JL04V-2E10SL-3PE-B-R	MS3106B32-17S (MS3057-20A) [MS06B32-17S-20]	MS3108B32-17S (MS3057-20A) [MS08B32-17S-20]	JL04V-6A21-17SE-EB-R (JL04-32CK-R) [332706X11]		
100mm	Q1AA10100D Q1AA10150D Q1AA10200D Q1AA10250D	JL04V-2E20-15PE-B-R	JL04V-2E10SL-3PE-B-R	MS3106B20-15S (MS3057-12A) [MS06B20-15S-12]	MS3108B20-15S (MS3057-12A) [MS08B20-15S-12]	JL04V-6A20-15SE-EB-R (JL04-2022CK-R) [332706X5]	JL04V-8A20-15SE-EB-R (JL04-2022CK-R) [332707X5]	
120mm	Q1AA12100D Q1AA12200D Q1AA12300D	JL04V-2E24-11PE-B-R	JL04V-2E10SL-3PE-B-R	MS3106B24-11S (MS3057-16A) [MS06B24-11S-16]	MS3108B24-11S (MS3057-16A) [MS08B24-11S-16]	JL04V-6A24-11SE-EB-R (JL04-2428CK-R) [332706X10]	JL04V-8A24-11SE-EB-R (JL04-2428CK-R) [332707X10]	
130mm	Q1AA13300D Q1AA13400D Q1AA13500D	JL04V-2E24-11PE-B-R	※ 4 (JL04V-2E10SL-3PE-B-R)	MS3106B24-11S (MS3057-16A) [MS06B24-11S-16]	MS3108B24-11S (MS3057-16A) [MS08B24-11S-16]	JL04V-6A24-11SE-EB-R (JL04-2428CK-R) [332706X10]	JL04V-8A24-11SE-EB-R (JL04-2428CK-R) [332707X10]	
180mm	Q2AA18200H	JL04V-2E24-11PE-B-R	※ 4 (JL04V-2E10SL-3PE-B-R)	MS3106B24-11S (MS3057-16A) [MS06B24-11S-16]	MS3108B24-11S (MS3057-16A) [MS08B24-11S-16]	JL04V-6A24-11SE-EB-R (JL04-2428CK-R) [332706X10]	JL04V-8A24-11SE-EB-R (JL04-2428CK-R) [332707X10]	
220mm	Q2AA22550B Q2AA22700S Q2AA2211KV Q2AA2215KV	JL04V-2E24-11PE-B-R JL04V-2E32-17PE-B-R	JL04V-2E10SL-3PE-B-R JL04V-2E10SL-3PE-B-R	MS3106B24-11S (MS3057-16A) [MS06B24-11S-16] MS3106B32-17S (MS3057-20A) [MS06B32-17S-20]	MS3108B24-11S (MS3057-16A) [MS08B24-11S-16] MS3108B32-17S (MS3057-20A) [MS08B32-17S-20]	JL04V-6A24-11SE-EB-R (JL04-2428CK-R) [332706X10] JL04V-6A32-17SE-EB-R (JL04-32CK-R) [332706X11]	JL04V-8A24-11SE-EB-R (JL04-2428CK-R) [332707X10]	

Voltage	Flange Size	Motor Model No.	TUV-Standard Plug for Brake Waterproof Specification (Cable Clamp) [Plug + Clamp]		Pin Layout Symbol				
			Straight	Angle	U phase	V phase	W phase	Ground	Brake
			200V Type	130mm	R2AA13050 R2AA13120 R2AA13180 R2AA13200	※ 3		D	E
180mm	R2AA18350 R2AA18450 R2AA18550 R2AA18750 R2AA1811K	JL04V-6A10SL-3SE-EB-R (JL04-1012CK-R) [332706X1]	JL04V-8A10SL-3SE-EB-R (JL04-1012CK-R) [332707X1]	※ 3	D	E	F	G, H	A, B
220mm	R2AA22350 R2AA22500	※ 3		D	E	F	G, H	A, B	
180mm	R1AA18550H R1AA18750H R1AA1811KR R1AA1815KB	JL04V-6A10SL-3SE-EB-R (JL04-1012CK-R) [332706X1]	JL04V-8A10SL-3SE-EB-R (JL04-1012CK-R) [332707X1]		A	B	C	D	A, B
100mm	Q1AA10100D Q1AA10150D Q1AA10200D Q1AA10250D	JL04V-6A10SL-3SE-EB-R (JL04-1012CK-R) [332706X1]	JL04V-8A10SL-3SE-EB-R (JL04-1012CK-R) [332707X1]		A	B	C	D	A, B
120mm	Q1AA12100D Q1AA12200D Q1AA12300D	JL04V-6A10SL-3SE-EB-R (JL04-1012CK-R) [332706X1]	JL04V-8A10SL-3SE-EB-R (JL04-1012CK-R) [332707X1]		D	E	F	G, H	A, B
130mm	Q1AA13300D Q1AA13400D Q1AA13500D	※ 4	※ 4		D	E	F	G, H	A, B
180mm	Q2AA18200H	※ 4	※ 4		D	E	F	G, H	A, B
220mm	Q2AA22550B Q2AA22700S Q2AA2211KV Q2AA2215KV	JL04V-6A10SL-3SE-EB-R (JL04-1012CK-R) [332706X1] JL04V-6A10SL-3SE-EB-R (JL04-1012CK-R) [332706X1]	JL04V-8A10SL-3SE-EB-R (JL04-1012CK-R) [332707X1] JL04V-8A10SL-3SE-EB-R (JL04-1012CK-R) [332707X1]		D	E	F	G, H	A, B

- ※ 1 : Please see the catalogs and instruction manuals of the connector manufacturer's (Japan Aviation Electronics Industry Limited) for details, including the instructions for the connector and the precautions.
- ※ 2 : [] indicates the SANYO DENKI part numbers (Plug & Cable Clamp)
- ※ 3 : The brake line is shared with the power receptacle.
- ※ 4 : Both power and brake connectors are required for all motors equipped with TUV compliant DC24V brakes.

Features and Functions
Model No. List - Model Number Nomenclature
System Configuration
Standard Specifications
Encoder Wiring Diagram
External Wiring Diagram
Dimensions
Setup Software
Option

Setup software, Serial Communication Relation

Name	Details	Model No.
1) Cable for personal computer communications	Between personal computer Analog / Pulse input type : CN2 and servo amplifier EtherCAT interface type : CN4	AL-00689703-01
2) Cable for communication between amp. (0.2m) ^{※1}	Servo Amplifier (CN2) ⇔ Servo Amplifier (CN3)	AL-00695974-01
3) Cable for communication between amp. (3.0m) ^{※1}		AL-00695974-02
4) Communication converter ^{※1}	RS-232C ⇔ RS-422	SAU-024-01
5) Connector with terminator ^{※1}	RS-422 terminator for communication	AL-00695977-01

Dimensions (Unit : mm)

1) Cable for personal computer communications (Model No. : AL-00689703-01)

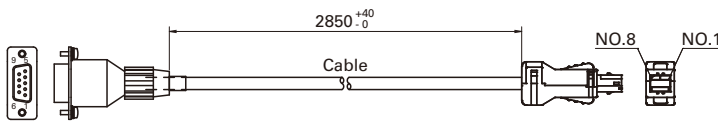

4) Communication converter (Model No. : SAU-024-01) ^{※1}

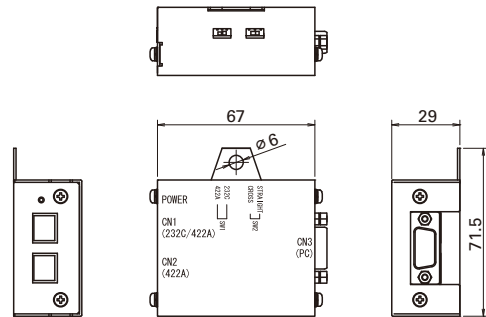

2) Cable for communication between amp. (0.2m) (Model No. : AL-00695974-01) ^{※1}

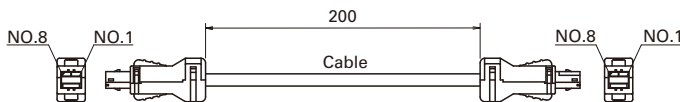

3) Cable for communication between amp. (3.0m) (Model No. : AL-00695974-02) ^{※1}

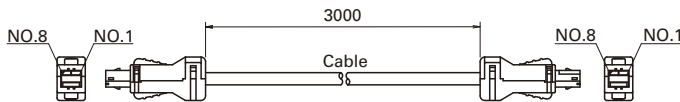

5) Connector with terminator (Model No. : AL-00695977-01) ^{※1}

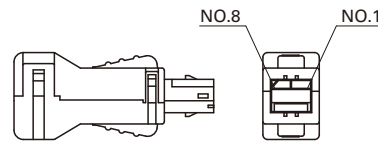

^{※1} Optional connector dedicated for analog/pulse input type.

Connection examples

1) For single axis

· When using PC RS-232C terminal

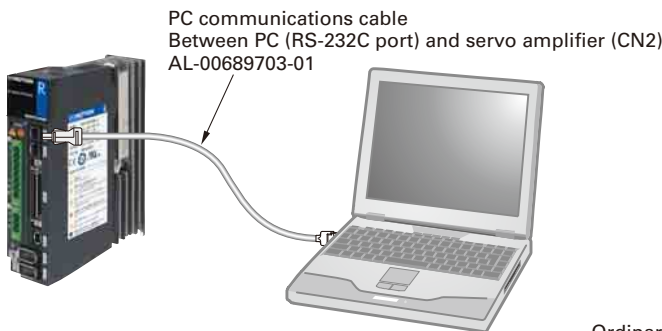

· When using PC USB terminal

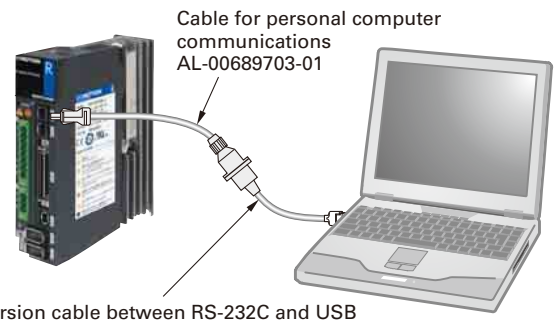

Ordinary conversion cable between RS-232C and USB

2) For multiple axes

Cable for communications between amplifiers
Between communications converter (CN1) or
servo amplifier (CN3) and servo amplifier (CN2)
AL-00695974-01 (0.2m) or AL-00695974-02 (3.0m)

- When using PC D-sub terminal: Ordinary RS-232C cable (straight or cross)
- When using PC USB terminal: Ordinary conversion cable between RS-232C and USB

* Communications converter CN3 is a D-sub 9-pin

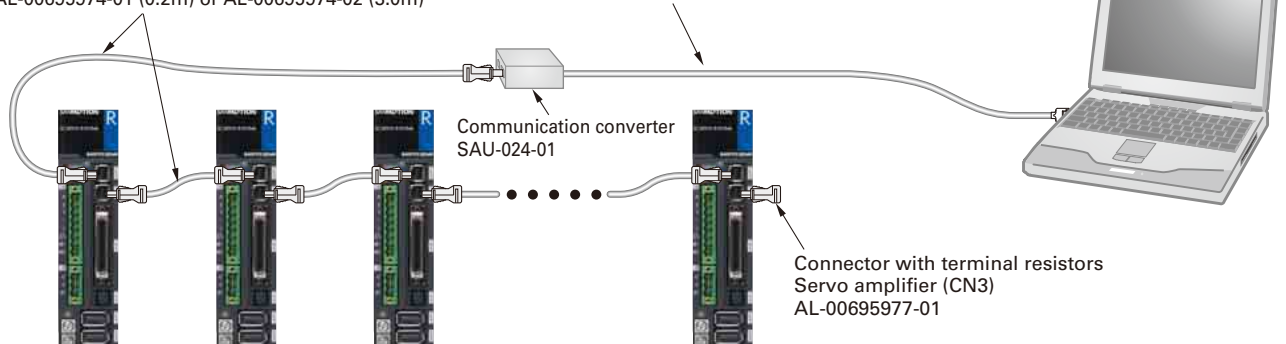

Battery for Battery Backup Method Absolute Encoder Relation

Name	Details	Model No.
1) Battery trunk cable, with connectors on both ends	—	AL-00731792-01
2) Battery trunk cable, with connectors on one end	—	AL-00697960-□□
3) Replacement batteries	Lithium battery : ER3VLY Toshiba Consumer Marketing Ltd.	AL-00697958-01

Dimensions (Unit : mm)

- 1) Battery trunk cable, with connectors on both ends
(Model No. : AL-00731792-01)

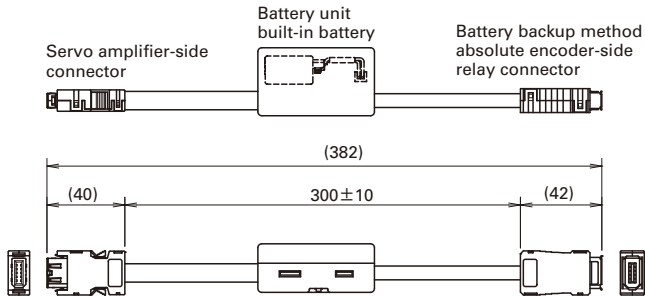

- 3) Replacement batteries (Model No. : AL-00697958-01)

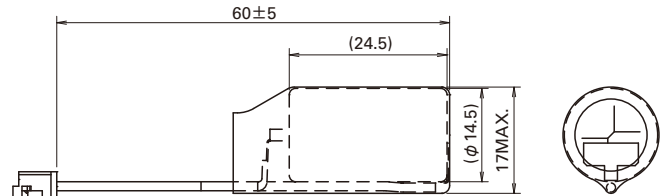

- 2) Battery trunk cable, with connectors on one end
(Model No. : AL-00697960-□□)

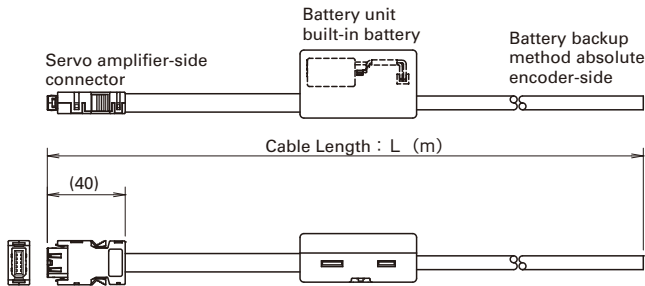

	Model No.	L [m]
1	AL-00697960-01	3
2	AL-00697960-02	5
3	AL-00697960-03	10
4	AL-00697960-04	15
5	AL-00697960-05	20
6	AL-00697960-06	25

Analog Monitor Relation

Name	Details	Model No.
1) Monitor Box	Monitor box body 2 dedicated cables	Q-MON-3
2) Dedicated cable	2 dedicated cables	AL-00690525-01

Dimensions (Unit : mm)

- 1) Monitor Box (Model No. : Q-MON-3)

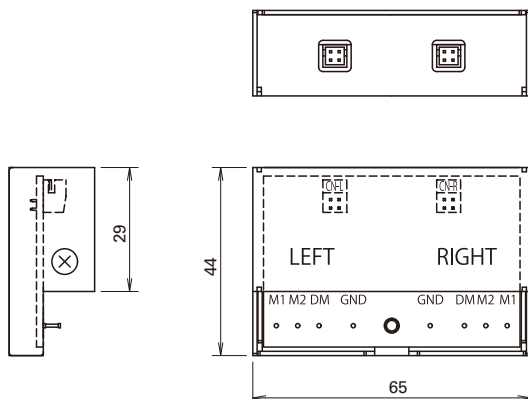

- 2) Dedicated Cable (Model No. : AL-00690525-01)

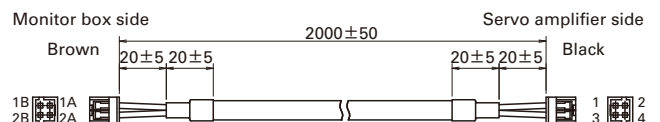

※1 2 units of the dedicated cables per above 2) (PN# AL-00690525-01) are attached to Monitor Box (PN#Q-MON-3).

Features and Functions

Model No. List - Model Number Nomenclature

System Configuration

Standard Specifications

Encoder Wiring Diagram

External Wiring Diagram

Dimensions

Setup Software

Option

External Regenerative Resistor Dimensions (Unit: mm)

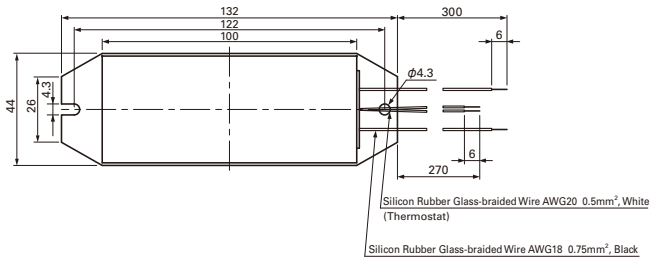

Mass : 0.19kg

	Model No.	Thermostat
1	REGIST-080W100B	Normal close
2	REGIST-080W50B	Normal close

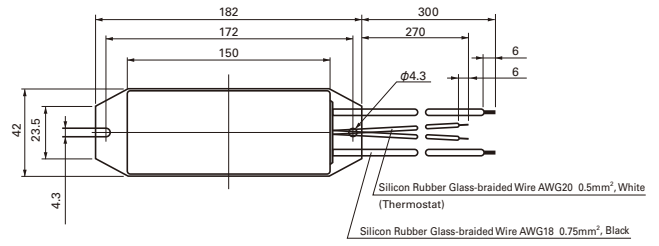

Mass : 0.24kg

	Model No.	Thermostat
1	REGIST-120W100B	Normal close
2	REGIST-120W50B	Normal close

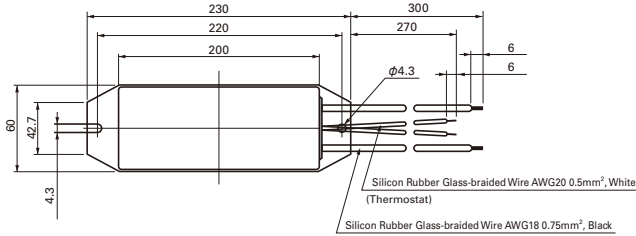

Mass : 0.44kg

	Model No.	Thermostat
1	REGIST-220W20B	Normal close
2	REGIST-220W50B	Normal close
3	REGIST-220W100B	Normal close

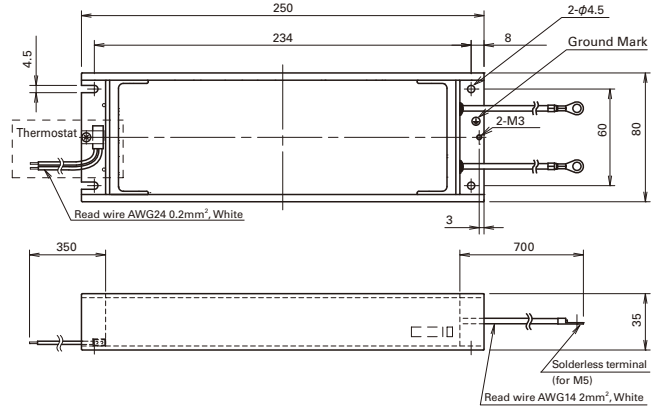

Mass : 1.5kg

	Model No.	Thermostat
1	REGIST-500CW20B	Normal close
2	REGIST-500CW14B	Normal close
3	REGIST-500CW10B	Normal close
4	REGIST-500CW7B	Normal close

Junction cable for servo motor

Power cable

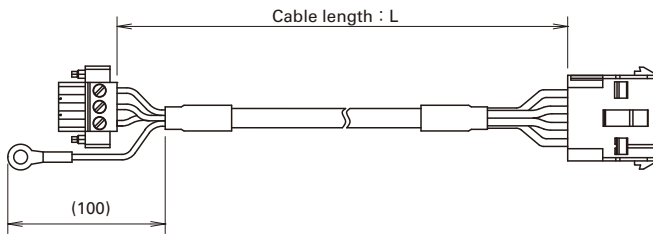

Brake cable

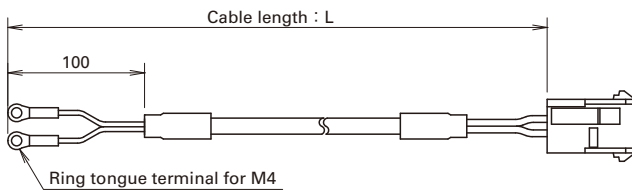

Encoder cable

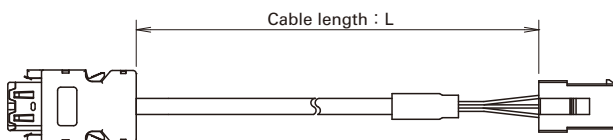

Model No.			Cable length : L (m)
Power cable	Brake cable	Encoder cable	
RS-CM4-01-R	RS-CB3-01-R	RS-CA4-01-R	1
RS-CM4-02-R	RS-CB3-02-R	RS-CA4-02-R	2
RS-CM4-03-R	RS-CB3-03-R	RS-CA4-03-R	3
RS-CM4-05-R	RS-CB3-05-R	RS-CA4-05-R	5
RS-CM4-10-R	RS-CB3-10-R	RS-CA4-10-R	10

Servo motor with connectors for junction cables

200V System

Rated output	Motor flange size	Holding brake	Model No.	Remarks
30W	40mm sq.	—	R2AA04003FXPA0	
30W	40mm sq.	yes (DC24V)	R2AA04003FCPA0	
50W	40mm sq.	—	R2AA04005FXPA0	
50W	40mm sq.	yes (DC24V)	R2AA04005FCPA0	
100W	40mm sq.	—	R2AA04010FXPA0	
90W	40mm sq.	yes (DC24V)	R2AA04010FCPA0	90% lower rating
100W	60mm sq.	—	R2AA06010FXPA0	
100W	60mm sq.	yes (DC24V)	R2AA06010FCPA0	
200W	60mm sq.	—	R2AA06020FXPA0	
200W	60mm sq.	yes (DC24V)	R2AA06020FCPA0	
400W	60mm sq.	—	R2AA06040FXPA0	
360W	60mm sq.	yes (DC24V)	R2AA06040FCPA0	90% lower rating
750W	80mm sq.	—	R2AA08075FXPA0	
750W	80mm sq.	yes (DC24V)	R2AA08075FCPA0	

• Connectors are connected as shown in the figure. The cable length is 200 ± 30 mm.

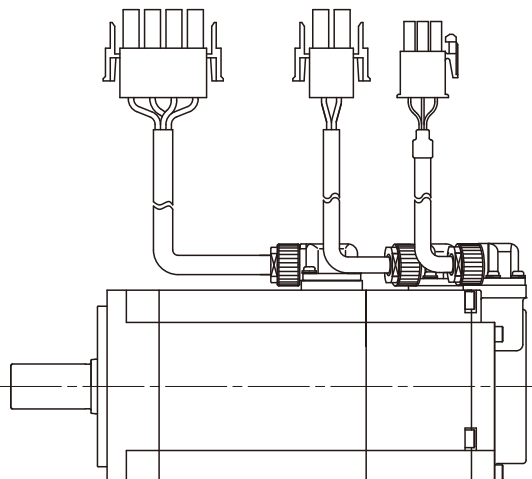

For more information regarding any products or services described here in, please contact your nearest office listed on the back of this catalog.

To SANYO DENKI Co.,LTD.

Date : _____

Company: _____

Department: _____

Name: _____

Tel: _____

FAX: _____

E-mail: _____

Item	Contents																																																																																																
①	Name of target equipment Equipment name, category (transport, processing, test, other)																																																																																																
②	Name of servo axis Axis name, axial mechanism (horizontal/vertical), brake mechanism (yes/no)																																																																																																
③	Current condition of above axis Manufacturer Name () Series Name () Motor Capacity () Hydraulic, Mechanical, or New System ()																																																																																																
④	Positioning accuracy \pm mm $\cdot\pm$ μ m																																																																																																
⑤	Operation pattern <div style="display: flex; align-items: center;"> <div style="flex: 1;"> <p style="font-size: small;">Feeding Speed [m/sec] vs Time [sec]. Acceleration α: ___ G ___ [m/s²] Feeding Speed V: ___ [m/s] Moving Distance D: ___ [m] (Stroke) Time intervals: t_1 (acceleration), t_2 (constant speed), t_3 (deceleration)</p> </div> <div style="flex: 1; padding-left: 10px;"> <p style="font-size: x-small;">[Reference formula] $1G=9.8[m/s^2]$, $1[m/s^2]\approx 0.1G$ $\alpha[m/s^2]=V[m/sec]\div t_1[sec]$ $D[m]=V[m/sec]\times(t_1+t_2)[sec]$</p> </div> </div>																																																																																																
⑥	Mechanism Ball-screw/screw-rotation type (horizontal/vertical), ball-screw/nut-rotation type (horizontal/vertical), rack and pinion (horizontal/vertical), belt/chain (horizontal/vertical), rotary table, roll feed, other																																																																																																
⑦	Mechanical structure <table style="width: 100%; font-size: x-small; border-collapse: collapse;"> <tr> <td>WT(table mass)</td><td>kg</td> <td>WL(work mass)</td><td>kg</td> <td>WA(mass of other drive parts)</td><td>kg</td> </tr> <tr> <td>WR(rack mass)</td><td>kg</td> <td>WB(belt/chain mass)</td><td>kg</td> <td>WC(counterbalance mass)</td><td>kg</td> </tr> <tr> <td>Fa(external force axial direction)</td><td>N</td> <td>Fb(ball-screw preload)</td><td>N</td> <td>T(roll pushing force)</td><td>N</td> </tr> <tr> <td>Dr1(drive-side roll diameter)</td><td>mm</td> <td>Dr2(follower-side roll diameter)</td><td>mm</td> <td></td><td></td> </tr> <tr> <td>Lr1(drive-side roll length)</td><td>mm</td> <td>Lr2(follower-side roll length)</td><td>mm</td> <td>G(reduction ratio)</td><td></td> </tr> <tr> <td>JG(speed-reducer inertia)</td><td>kg·m²</td> <td>JC(coupling inertia)</td><td>kg·m²</td> <td></td><td></td> </tr> <tr> <td>JN(nut inertia)</td><td>kg·m²</td> <td>JO(other motor-axis conversion inertia)</td><td>kg·m²</td> <td></td><td></td> </tr> <tr> <td>Db(ball-screw diameter)</td><td>mm</td> <td>Lb(ball-screw axial length)</td><td>mm</td> <td>Pb(ball-screw lead)</td><td>mm</td> </tr> <tr> <td>Dp(pinion/pulley diameter)</td><td>mm</td> <td>Lp(pinion axial length)</td><td>mm</td> <td>tp(pully thickness)</td><td>mm</td> </tr> <tr> <td>Dt(table diameter)</td><td>mm</td> <td>Dh(table-support diameter)</td><td>mm</td> <td>LW(load shift from axis)</td><td>mm</td> </tr> <tr> <td>Ds(table shaft diameter)</td><td>mm</td> <td>Ls(table shaft length)</td><td>mm</td> <td></td><td></td> </tr> <tr> <td>ρ(specific gravity of ball-screw/pinion/pulley/table-shaft material)</td><td>kg·cm³</td> <td></td><td></td> <td></td><td></td> </tr> <tr> <td>μ(friction coefficient between sheet and shilding-surface/support-section/roll)</td><td></td> <td>$\rho 1$(specific gravity of roll-1 material)</td><td>kg/cm³</td> <td></td><td></td> </tr> <tr> <td>$\rho 2$(specific gravity of roll-2 material)</td><td>kg/cm³</td> <td>κ(internal friction coefficient of preload nut)</td><td></td> <td></td><td></td> </tr> <tr> <td>η(mechanical efficiency)</td><td></td> <td>JL(load inertia of motor-axis conversion)</td><td>kg·m²</td> <td></td><td></td> </tr> <tr> <td>TF(friction torque of motor axis conversion)</td><td>N·m</td> <td>Tu(imbalance torque of motor axis conversion)</td><td>N·m</td> <td></td><td></td> </tr> </table>	WT(table mass)	kg	WL(work mass)	kg	WA(mass of other drive parts)	kg	WR(rack mass)	kg	WB(belt/chain mass)	kg	WC(counterbalance mass)	kg	Fa(external force axial direction)	N	Fb(ball-screw preload)	N	T(roll pushing force)	N	Dr1(drive-side roll diameter)	mm	Dr2(follower-side roll diameter)	mm			Lr1(drive-side roll length)	mm	Lr2(follower-side roll length)	mm	G(reduction ratio)		JG(speed-reducer inertia)	kg·m ²	JC(coupling inertia)	kg·m ²			JN(nut inertia)	kg·m ²	JO(other motor-axis conversion inertia)	kg·m ²			Db(ball-screw diameter)	mm	Lb(ball-screw axial length)	mm	Pb(ball-screw lead)	mm	Dp(pinion/pulley diameter)	mm	Lp(pinion axial length)	mm	tp(pully thickness)	mm	Dt(table diameter)	mm	Dh(table-support diameter)	mm	LW(load shift from axis)	mm	Ds(table shaft diameter)	mm	Ls(table shaft length)	mm			ρ (specific gravity of ball-screw/pinion/pulley/table-shaft material)	kg·cm ³					μ (friction coefficient between sheet and shilding-surface/support-section/roll)		$\rho 1$ (specific gravity of roll-1 material)	kg/cm ³			$\rho 2$ (specific gravity of roll-2 material)	kg/cm ³	κ (internal friction coefficient of preload nut)				η (mechanical efficiency)		JL(load inertia of motor-axis conversion)	kg·m ²			TF(friction torque of motor axis conversion)	N·m	Tu(imbalance torque of motor axis conversion)	N·m		
WT(table mass)	kg	WL(work mass)	kg	WA(mass of other drive parts)	kg																																																																																												
WR(rack mass)	kg	WB(belt/chain mass)	kg	WC(counterbalance mass)	kg																																																																																												
Fa(external force axial direction)	N	Fb(ball-screw preload)	N	T(roll pushing force)	N																																																																																												
Dr1(drive-side roll diameter)	mm	Dr2(follower-side roll diameter)	mm																																																																																														
Lr1(drive-side roll length)	mm	Lr2(follower-side roll length)	mm	G(reduction ratio)																																																																																													
JG(speed-reducer inertia)	kg·m ²	JC(coupling inertia)	kg·m ²																																																																																														
JN(nut inertia)	kg·m ²	JO(other motor-axis conversion inertia)	kg·m ²																																																																																														
Db(ball-screw diameter)	mm	Lb(ball-screw axial length)	mm	Pb(ball-screw lead)	mm																																																																																												
Dp(pinion/pulley diameter)	mm	Lp(pinion axial length)	mm	tp(pully thickness)	mm																																																																																												
Dt(table diameter)	mm	Dh(table-support diameter)	mm	LW(load shift from axis)	mm																																																																																												
Ds(table shaft diameter)	mm	Ls(table shaft length)	mm																																																																																														
ρ (specific gravity of ball-screw/pinion/pulley/table-shaft material)	kg·cm ³																																																																																																
μ (friction coefficient between sheet and shilding-surface/support-section/roll)		$\rho 1$ (specific gravity of roll-1 material)	kg/cm ³																																																																																														
$\rho 2$ (specific gravity of roll-2 material)	kg/cm ³	κ (internal friction coefficient of preload nut)																																																																																															
η (mechanical efficiency)		JL(load inertia of motor-axis conversion)	kg·m ²																																																																																														
TF(friction torque of motor axis conversion)	N·m	Tu(imbalance torque of motor axis conversion)	N·m																																																																																														
⑧	Speed reducer Customer-provided (/)-Sanyo denki standard(planet/spur/no-backlash-planet /) other(/)																																																																																																
⑨	Encoder type Encoder type specified (yes / no) Yes:(Wiring saving incremental encoder, battery backup absolute encoder, absolute encoder for incremental system, battery-less absolute encoder) Resolution()																																																																																																
⑩	Input format Position , velocity , torque , other ()																																																																																																
⑪	Host equipment (controller) Sequencer , laptop , customer-developed product , Sanyo denki-provided , other ()																																																																																																
⑫	Usage environment and other requirements Cutting , clean-room use , anti-dust measures , other ()																																																																																																
⑬	Estimated production Single product: () units/month () units/year																																																																																																
⑭	Development schedule Prototype period: ()Year () Month Production period: ()Year () Month																																																																																																
⑮	Various measures Related documentation (already submitted; send later by mail) Visit/PR desired (yes / no) Meeting desired (yes / no)																																																																																																
⑯	Miscellaneous (questions, pending problems, unresolved issues, etc.)																																																																																																

■ ECO PRODUCTS



ECO PRODUCTS are designed with the goal of lessening nevironmental impact, from product development to disposal.

■ Precautions For Adoption

Failure to follow the precautions on the right may cause moderate injury and property damage, or in some circumstances, could lead to a serious accident. Always follow all listed precautions.

⚠ Cautions

- Read the accompanying Instruction Manual carefully prior to using the product.
- If applying to medical devices and other equipment affecting people's lives, please contact us beforehand and take appropriate safety measures.
- If applying to equipment that can have significant effects on society and the general public, please contact us beforehand.
- Do not use this product in an environment where vibration is present, such as in a moving vehicle or shipping vessel.
- Do not perform any retrofitting, re-engineering, or modification to this equipment.
- The products presented in this catalog are meant to be used for general industrial applications. If using for special applications related to aviation and space, nuclear power, electric power, submarine repeaters, etc., please contact us beforehand.

*For any question or inquiry regarding the above, contact our Sales Department.

SANYO DENKI CO., LTD.

1-15-1, Kita-Otsuka, Toshima-ku, Tokyo 170-8451, Japan

<http://www.sanyodenki.com>

Phone: +81 3 3917 5157

SANYO DENKI AMERICA, INC.

468 Amapola Avenue Torrance, CA 90501 U.S.A.

Phone: +1 310 783 5400

SANYO DENKI EUROPE SA.

P.A. Paris Nord II, 48 Allée des Erables-VILLEPINTE, BP57286, F-95958 ROISSY CDG Cedex, France

Phone: +33 1 48 63 26 61

SANYO DENKI GERMANY GmbH

Frankfurter Strasse 92, 65760 Eschborn, Germany

Phone: +49 6196 76113 0

SANYO DENKI KOREA CO., LTD.

9F 5-2, Sunwha-dong Jung-gu Seoul, 100-130, Korea

Phone: +82 2 773 5623

SANYO DENKI SHANGHAI CO., LTD.

Rm2107-2109, Bldg A, Far East International Plaza, No.319, Xianxia Rd., Shanghai, 200051, China

Phone: +86 21 6235 1107

SANYO DENKI TAIWAN CO., LTD.

Room 1208, 12F, No.96 Chung Shan N, Rd., Sec.2, Taipei 104, Taiwan, R.O.C.

Phone: +886 2 2511 3938

SANYO DENKI (H.K.) CO., LIMITED

Room 2305, 23/F, South Tower, Concordia Plaza, 1 Science Museum Rd., TST East, Kowloon, Hong Kong

Phone: +852 2312 6250

SANYO DENKI SINGAPORE PTE. LTD.

10, Hoe Chiang Road, #14-03A/04, Keppel Towers, Singapore 089315

Phone: +65 6223 1071

The names of companies and/or their products specified in this catalog are the trade names, and/or trademarks and/or registered trademarks of such respective companies.

*Remarks : Specifications Are Subject To Change Without Notice.

CATALOG NO. S0944B003 '12.9.IT